

CURSO GRATUITO LAB:LAB

FOTOGRAFIA ANALÓGICA

COMPLETA

AULA 02

A CÂMERA

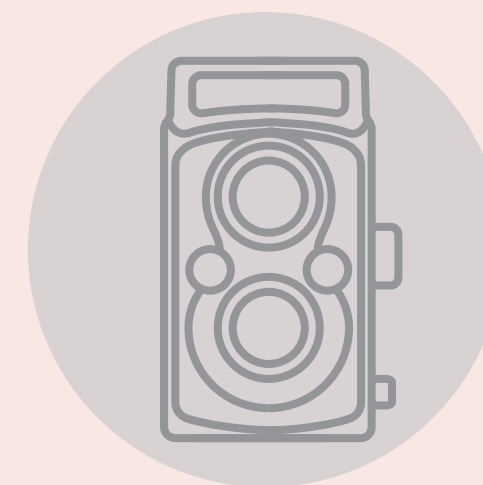
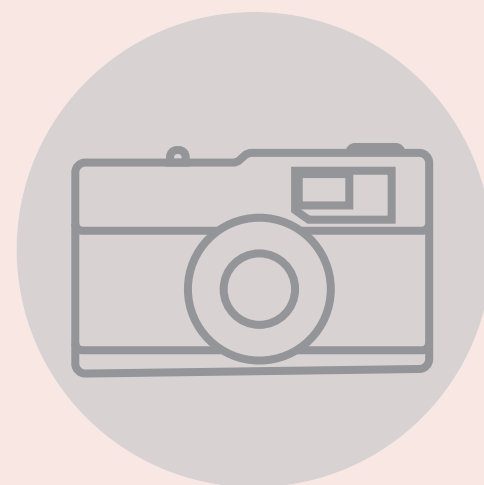
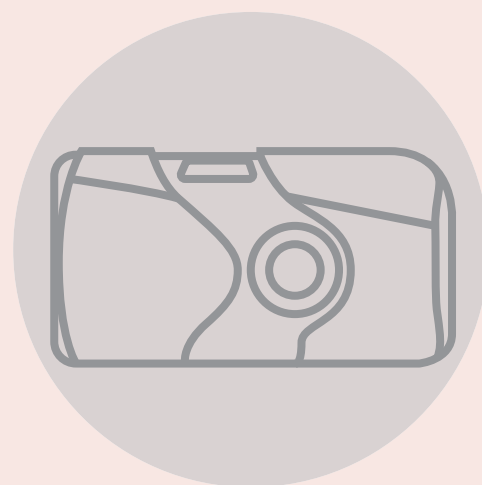

WEBCAM

CENA E PROJEÇÃO

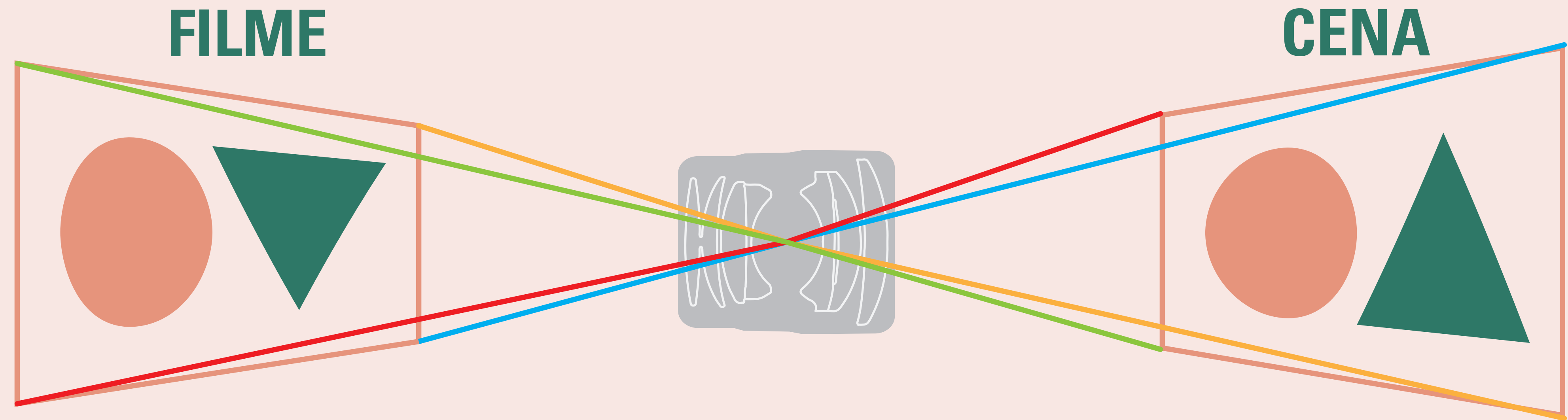

WEBCAM

CENA E PROJEÇÃO

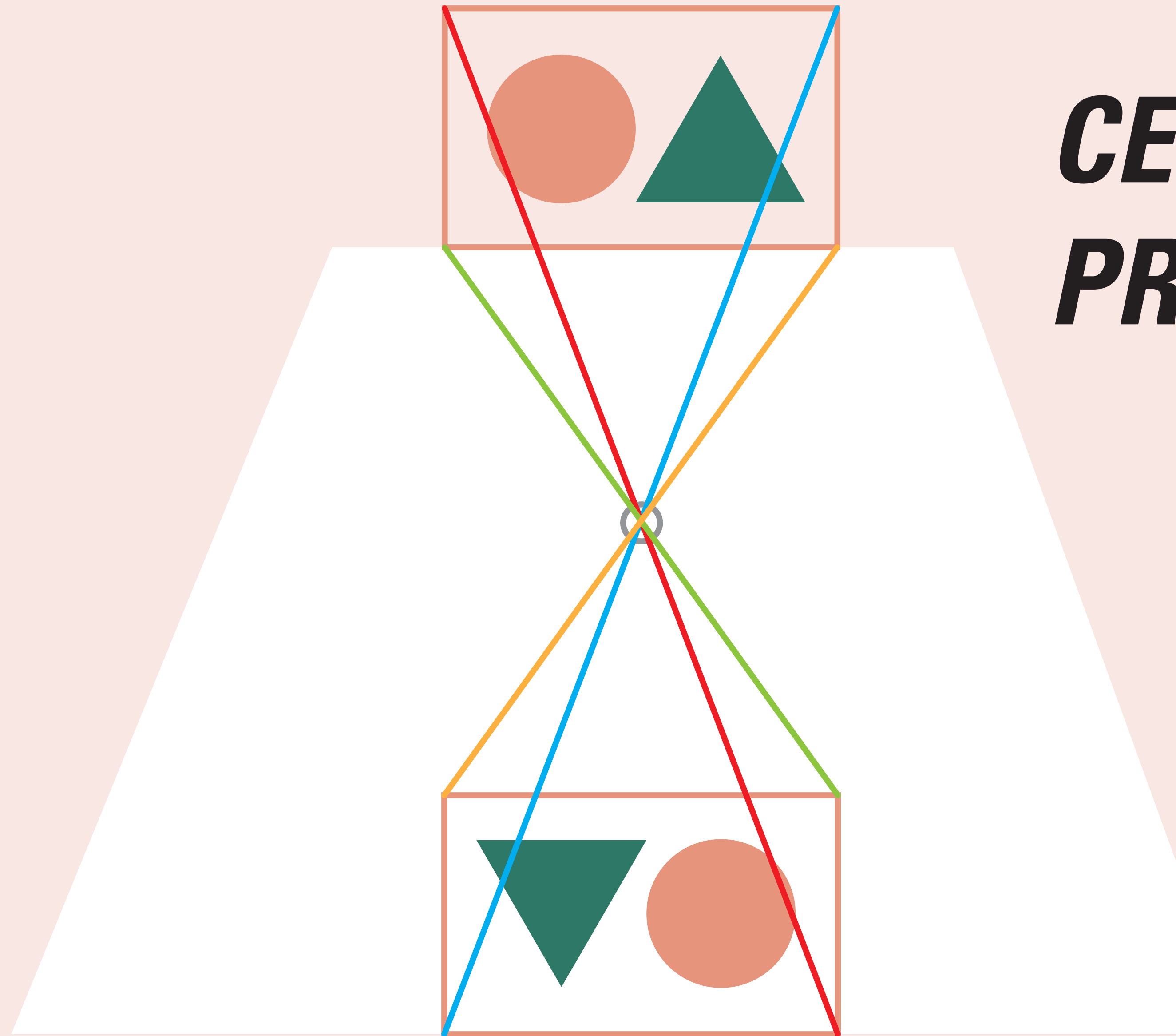

WEBCAM

CENA E PROJEÇÃO

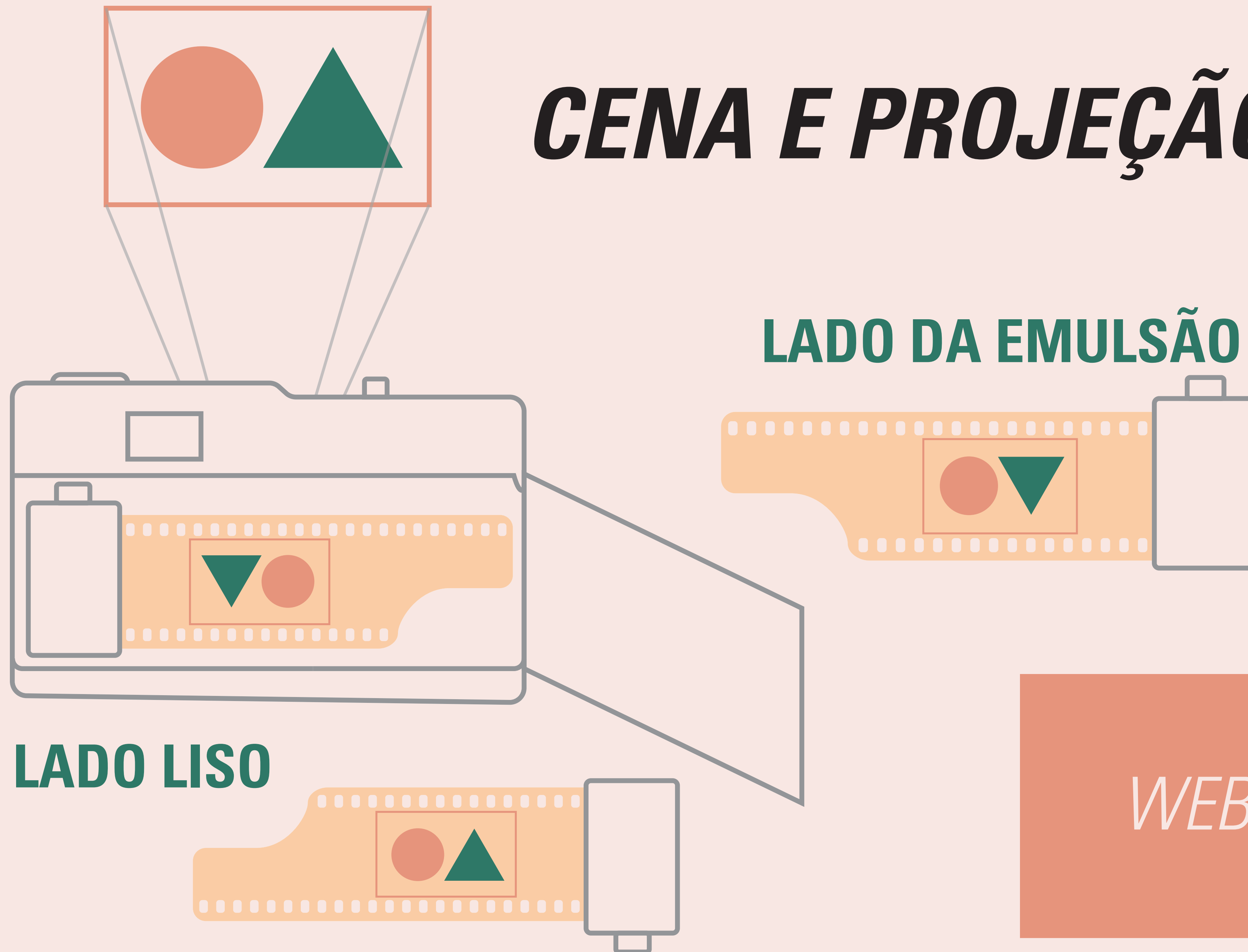

FORMATOS DE FILME MAIS COMUNS

PEQUENO

MÉDIO

GRANDE



110
16mm



135
35mm



126
35mm



120/220
62mm



620
60mm



127
40mm

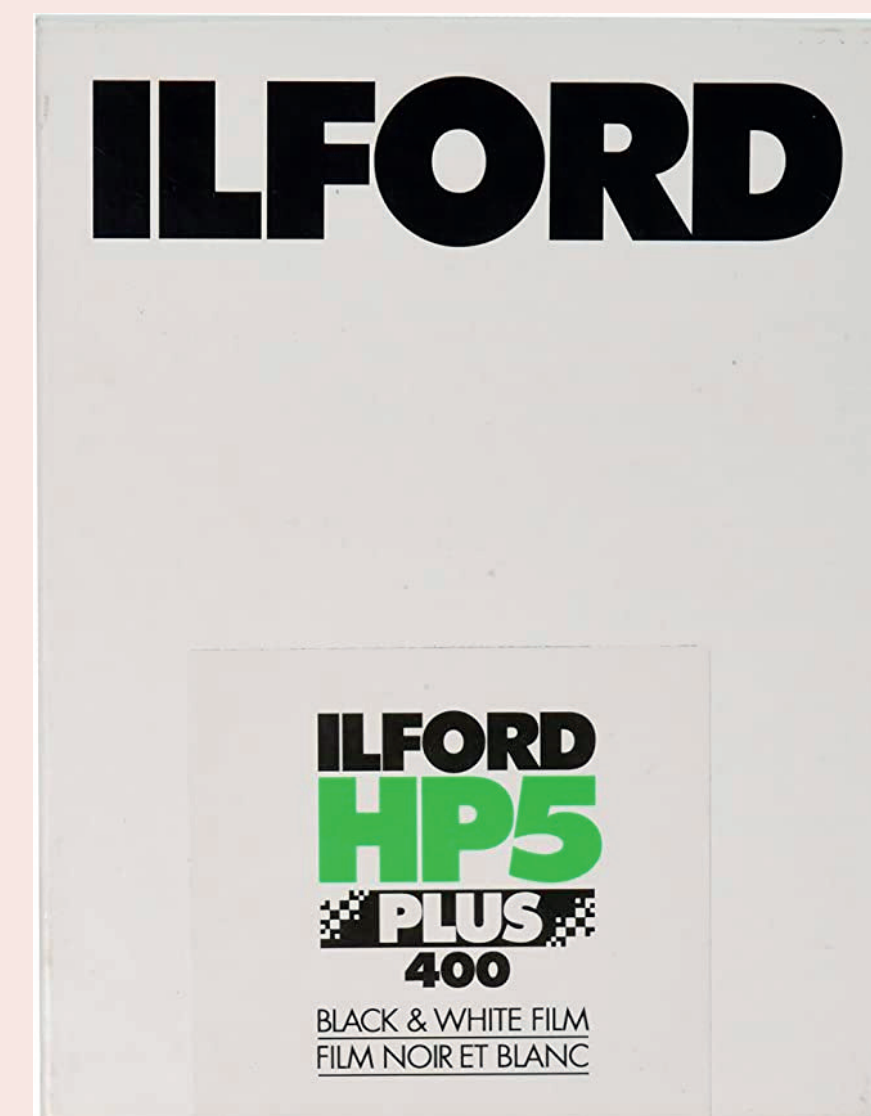

4x5" 10,15cm x 12,7cm

WEBCAM

COMPARATIVO DE FORMATOS EM ESCALA

4x5"
124cm²

120
6x4,5
27cm²

120
6x6
36cm²

120
6x7
42cm²

135
8,6cm²

110
2,5cm²

WEBCAM

TIPOS DE CÂMERA PEQUENO FORMATO

SLR - SINGLE LENS REFLEX



WEBCAM

TIPOS DE CÂMERA PEQUENO FORMATO

SLR - SINGLE LENS REFLEX

REFLEXÍVEL DE LENTE ÚNICA

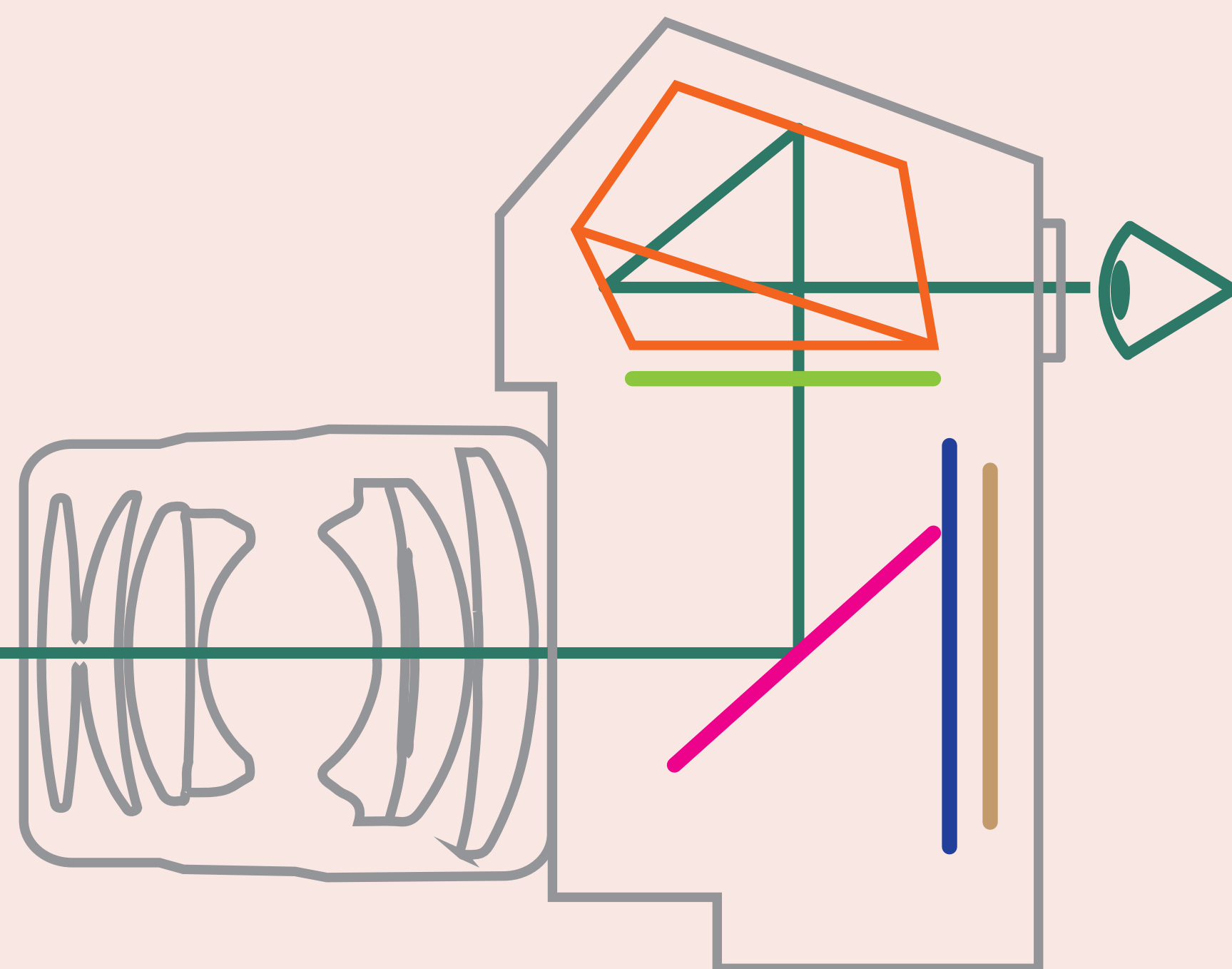

- PENTAPRISMA
- ESPELHO
- OBTURADOR
- FILME
- DESPOLIDO ou TELA DE FOCAGEM

WEBCAM

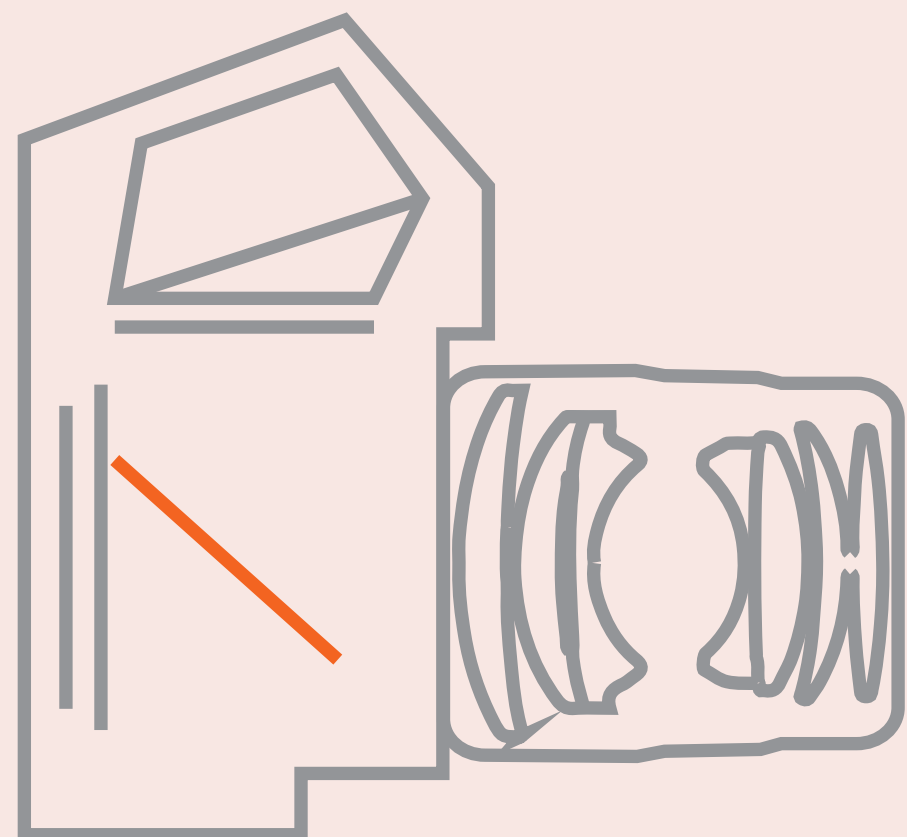

ESPELHO



Fonte: Videohive

**FUNÇÃO:
REFLETIR A IMAGEM
PROJETADA PELALENTE
PARA O DESPOLIDO.**

MATERIAL: CRISTAL ESPELHADO.

WEBCAM



DESPOLIDO

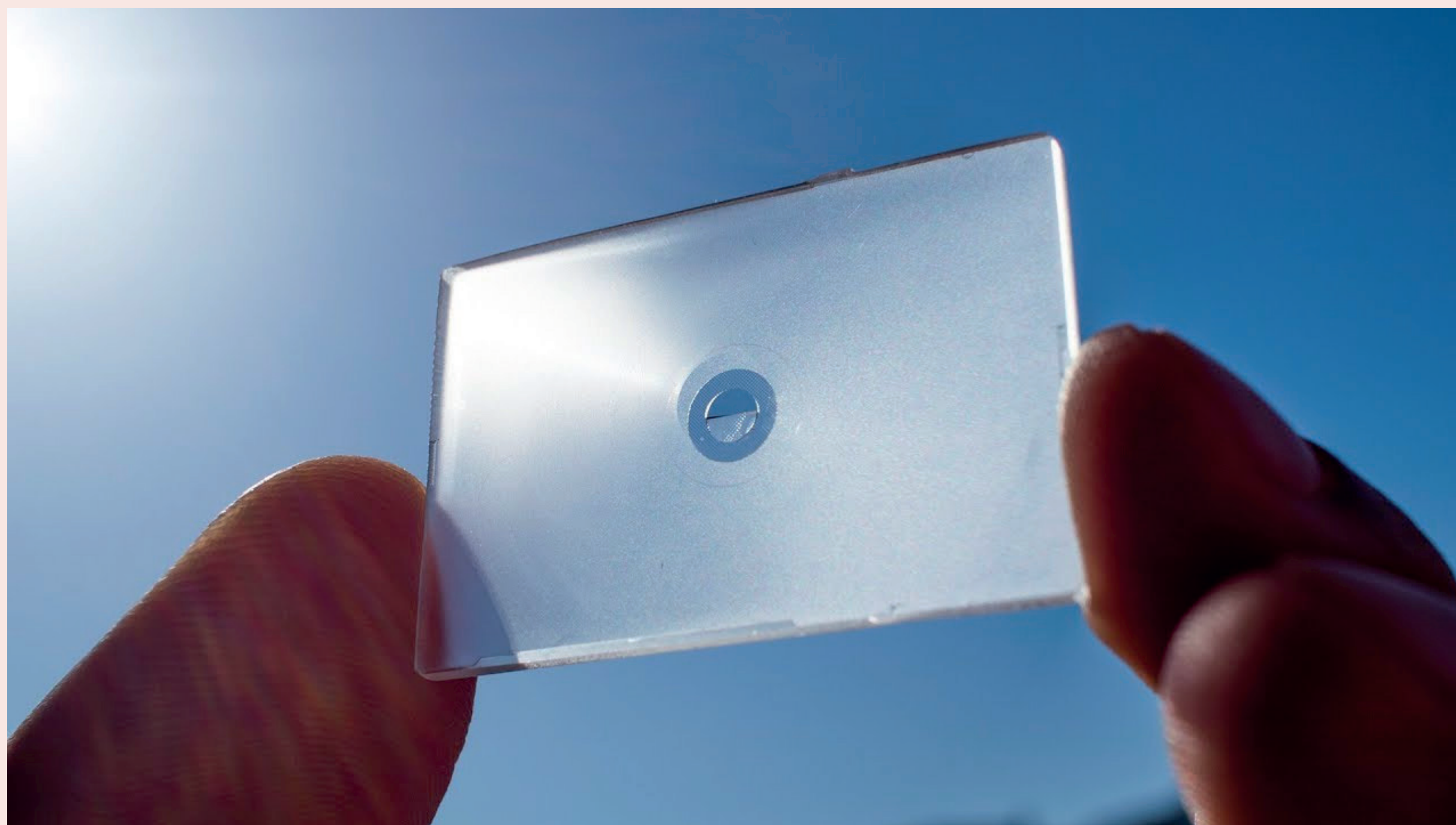

FUNÇÃO:
**ABSORVER A IMAGEM REFLETIDA DO
ESPELHO E AUXILIAR NA FOCAGEM.**

**MATERIAL: PLÁSTICO, ACRÍLICO OU VIDRO
COM UMA FACE JATEADA.**

Fonte: Camerahoarders

WEBCAM

FOCAGEM NO DESPOLIDO

BIPARTIDO: FOCAGEM POR DIVISÃO DE CAMPO

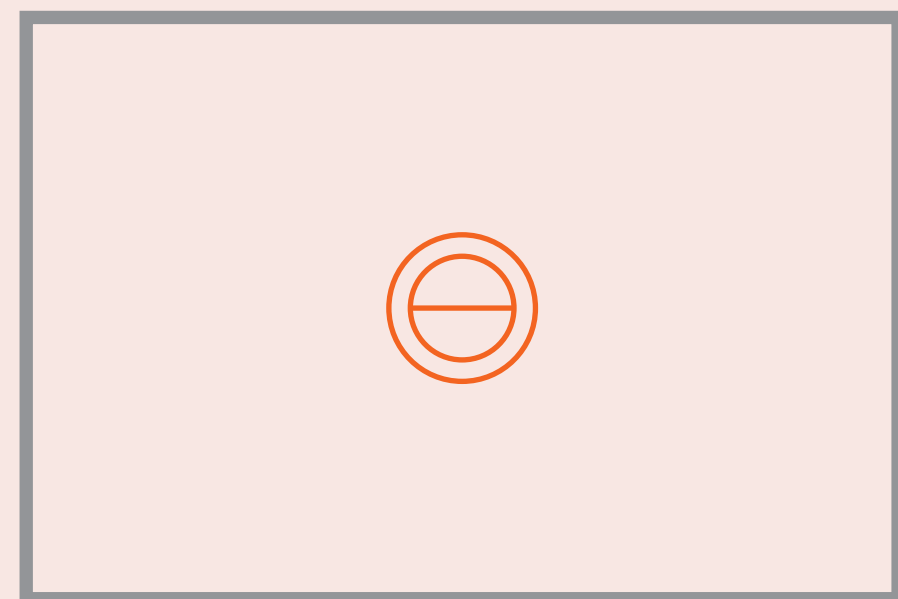
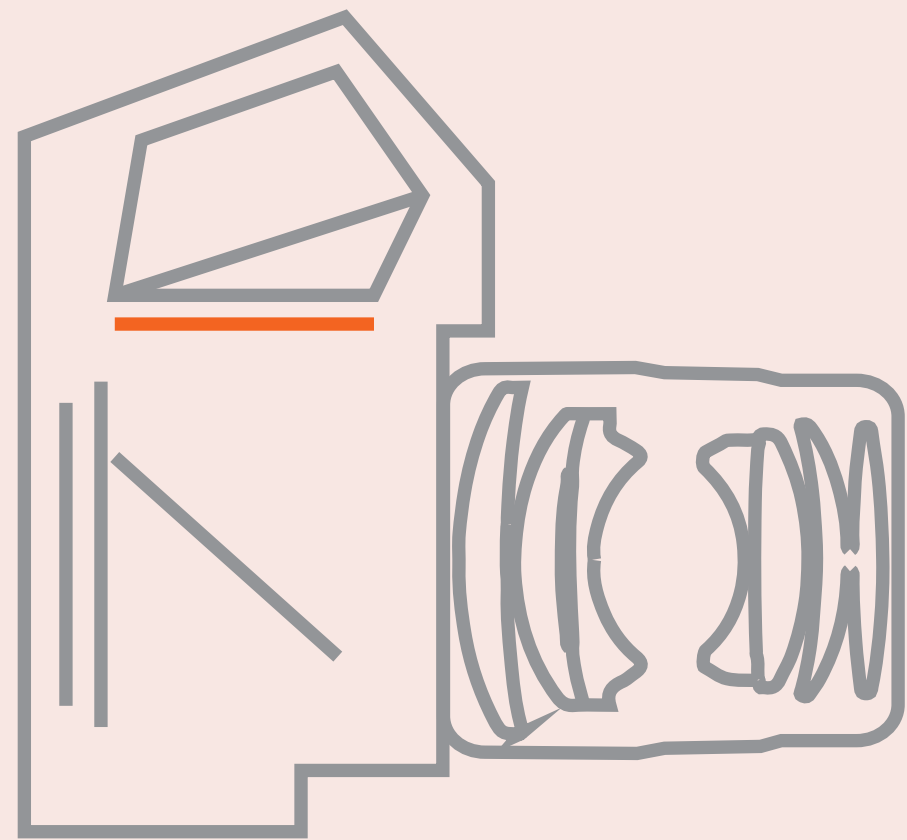

DESFOCADO

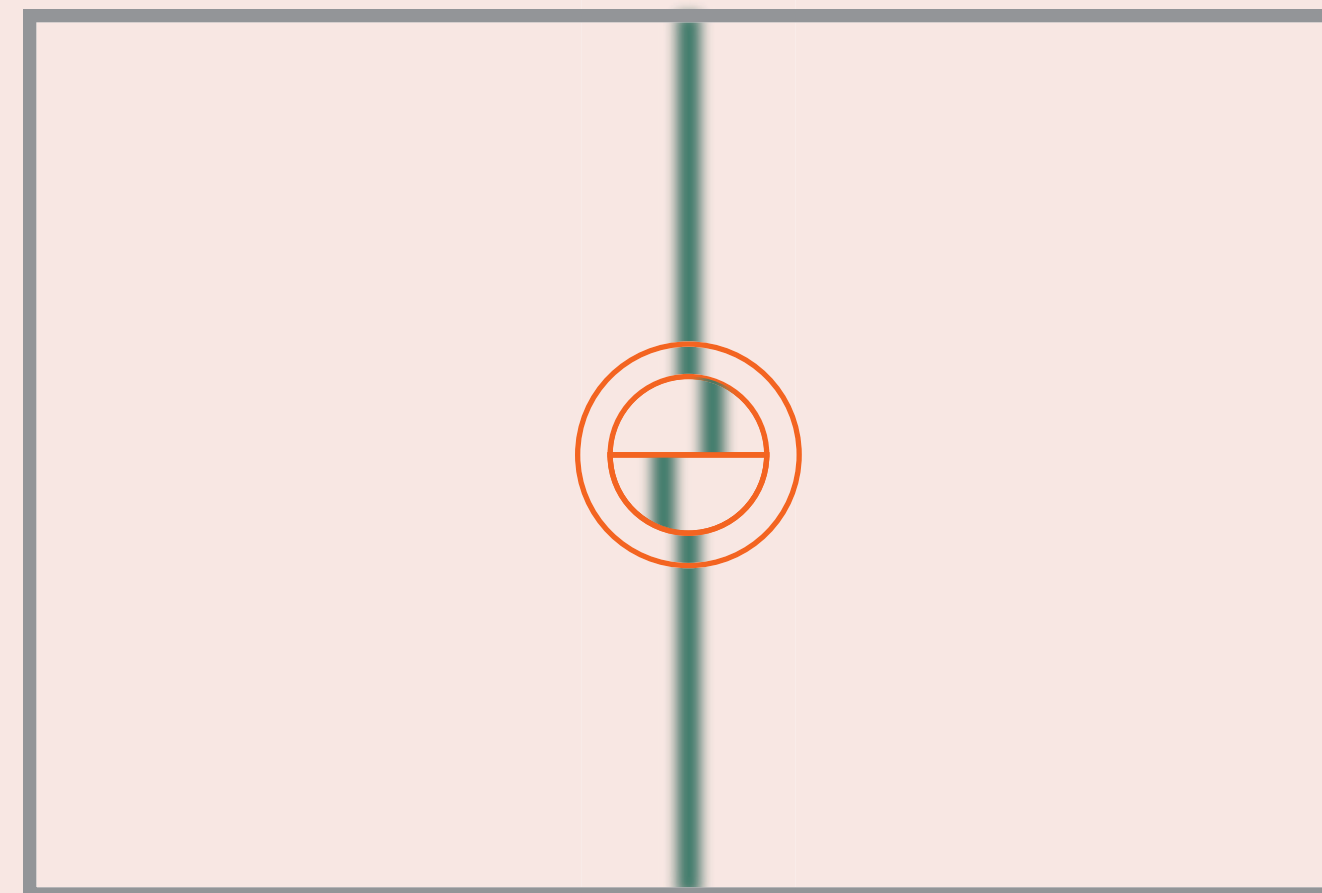
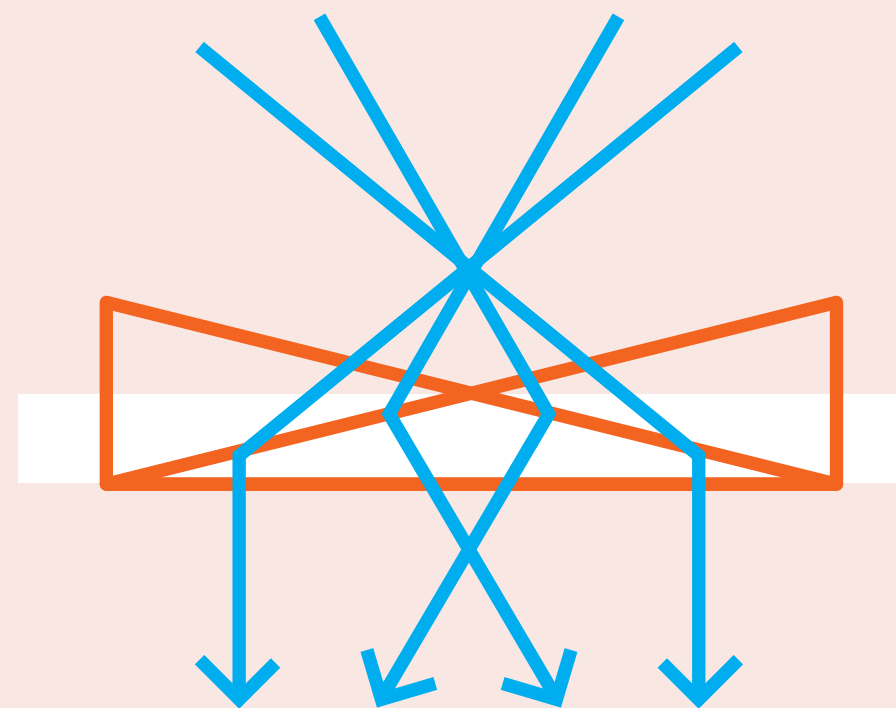

FOCADO

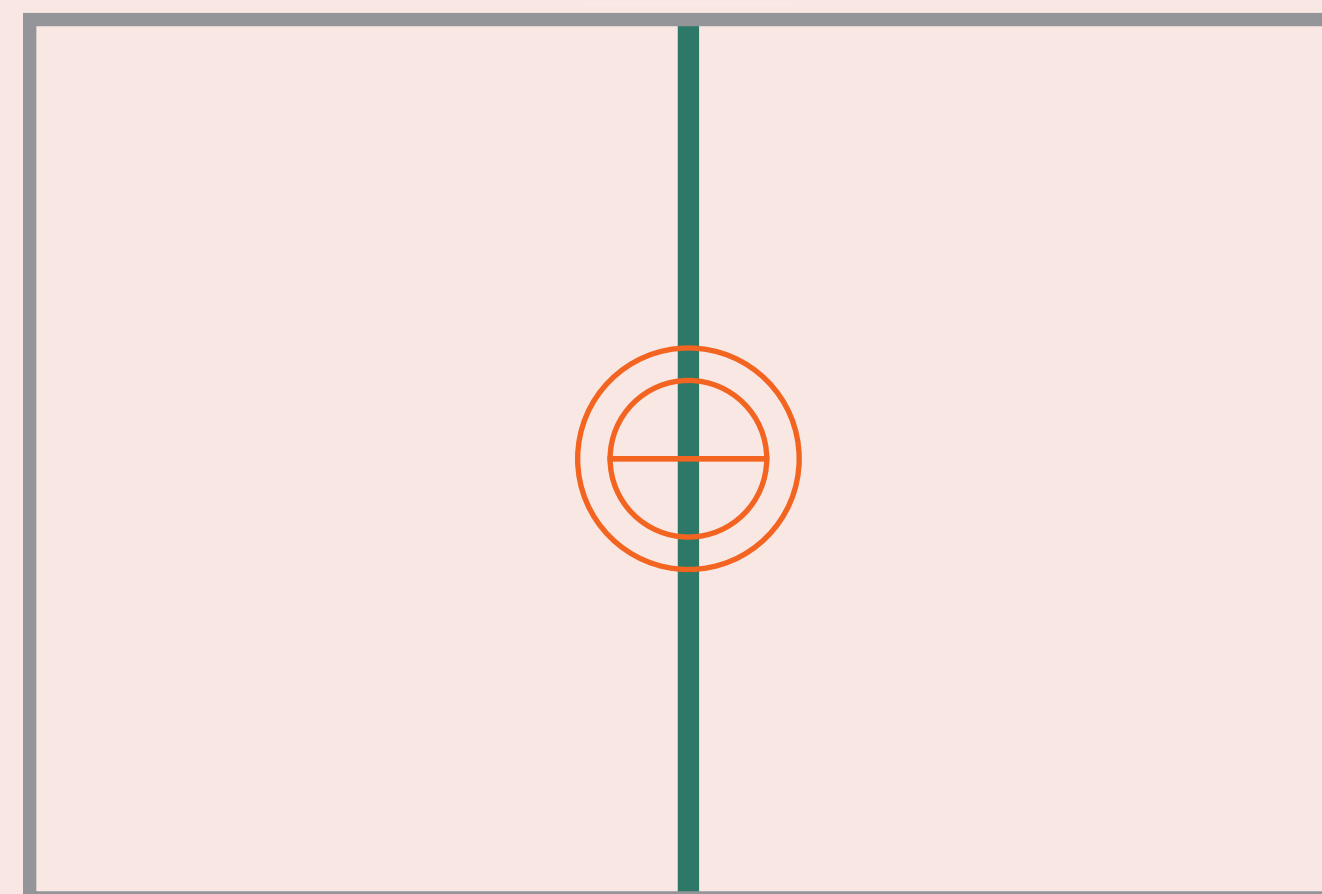
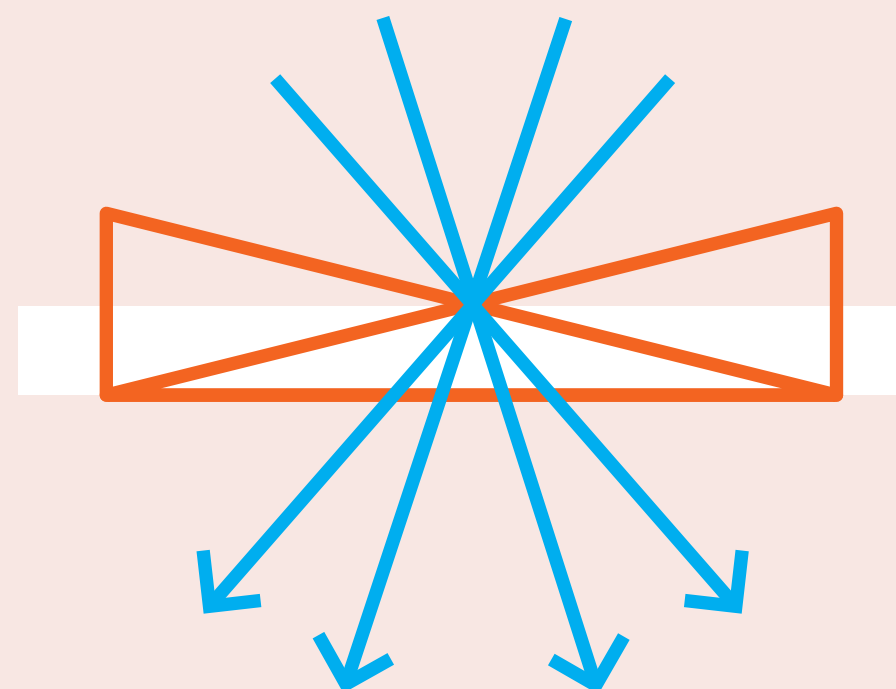

WEBCAM

FOCAGEM NO DESPOLIDO

ANÉIS DE MICROPRISMA

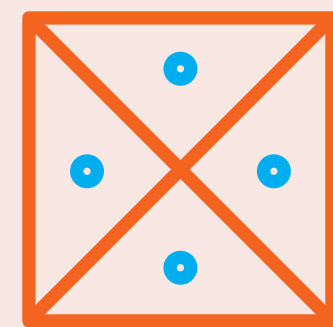
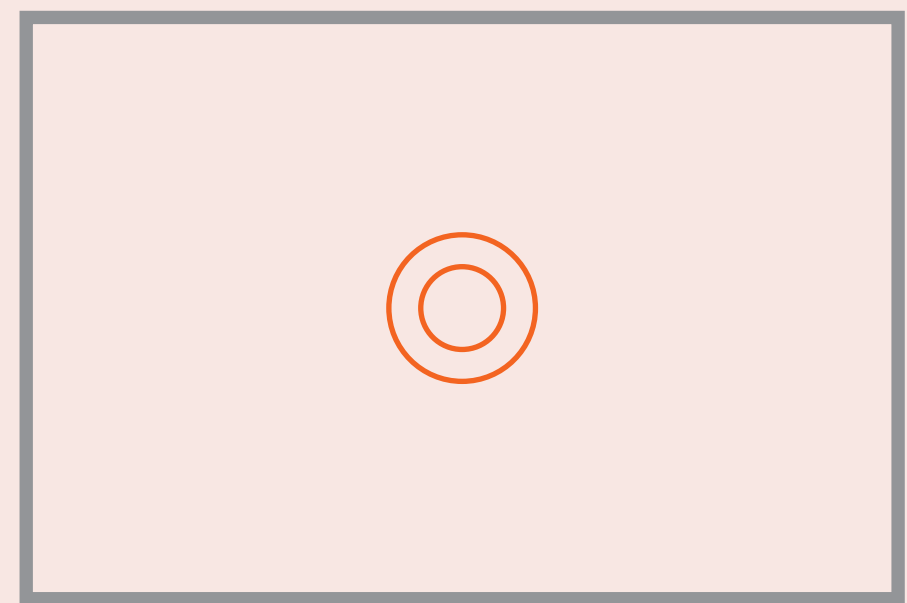
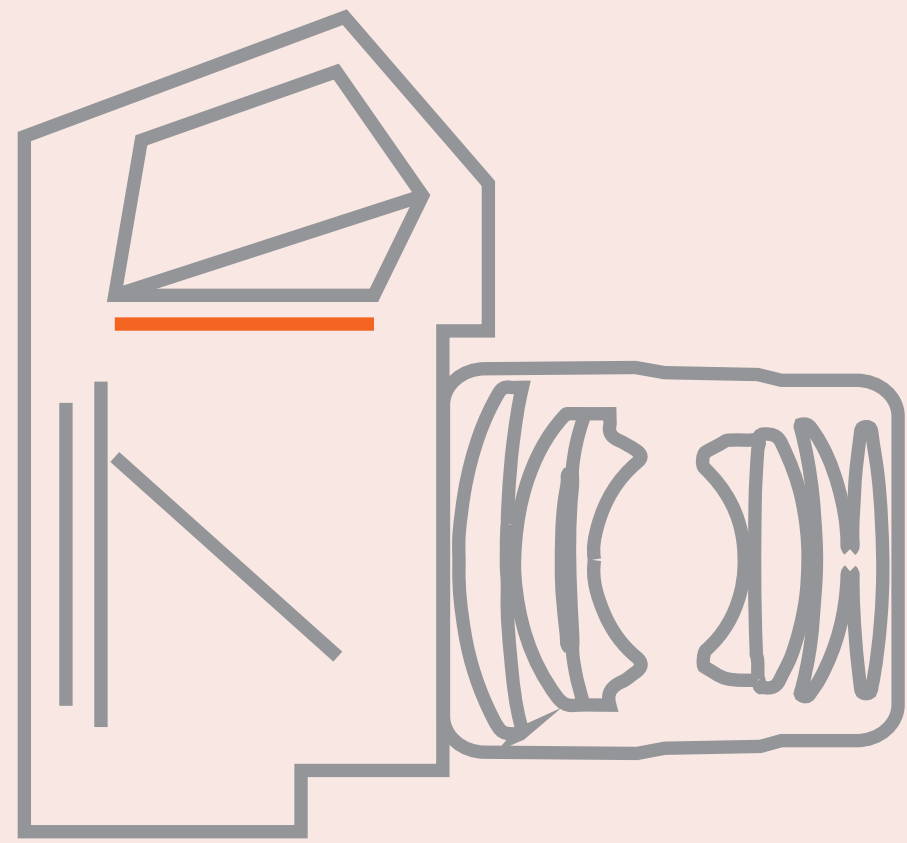

DESFOCADO

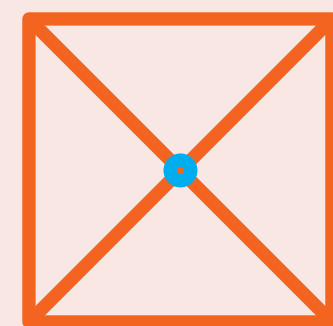
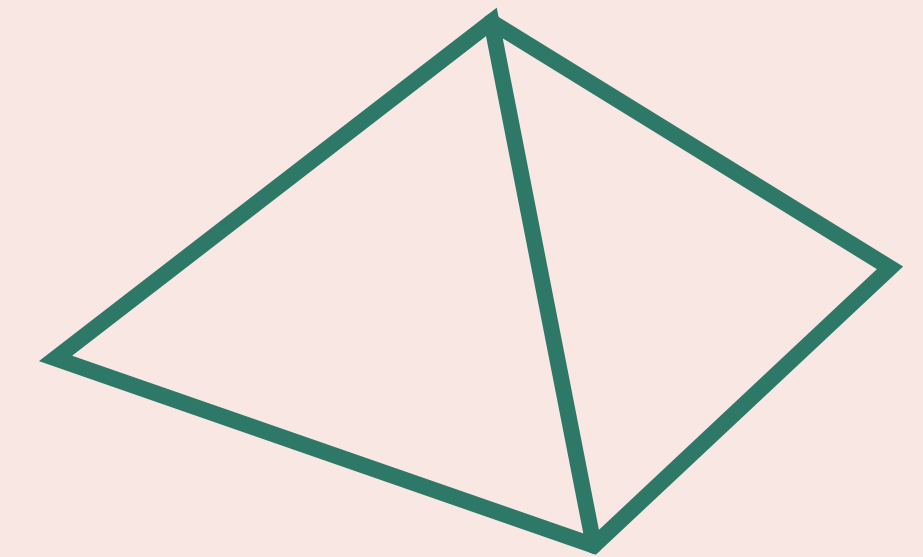
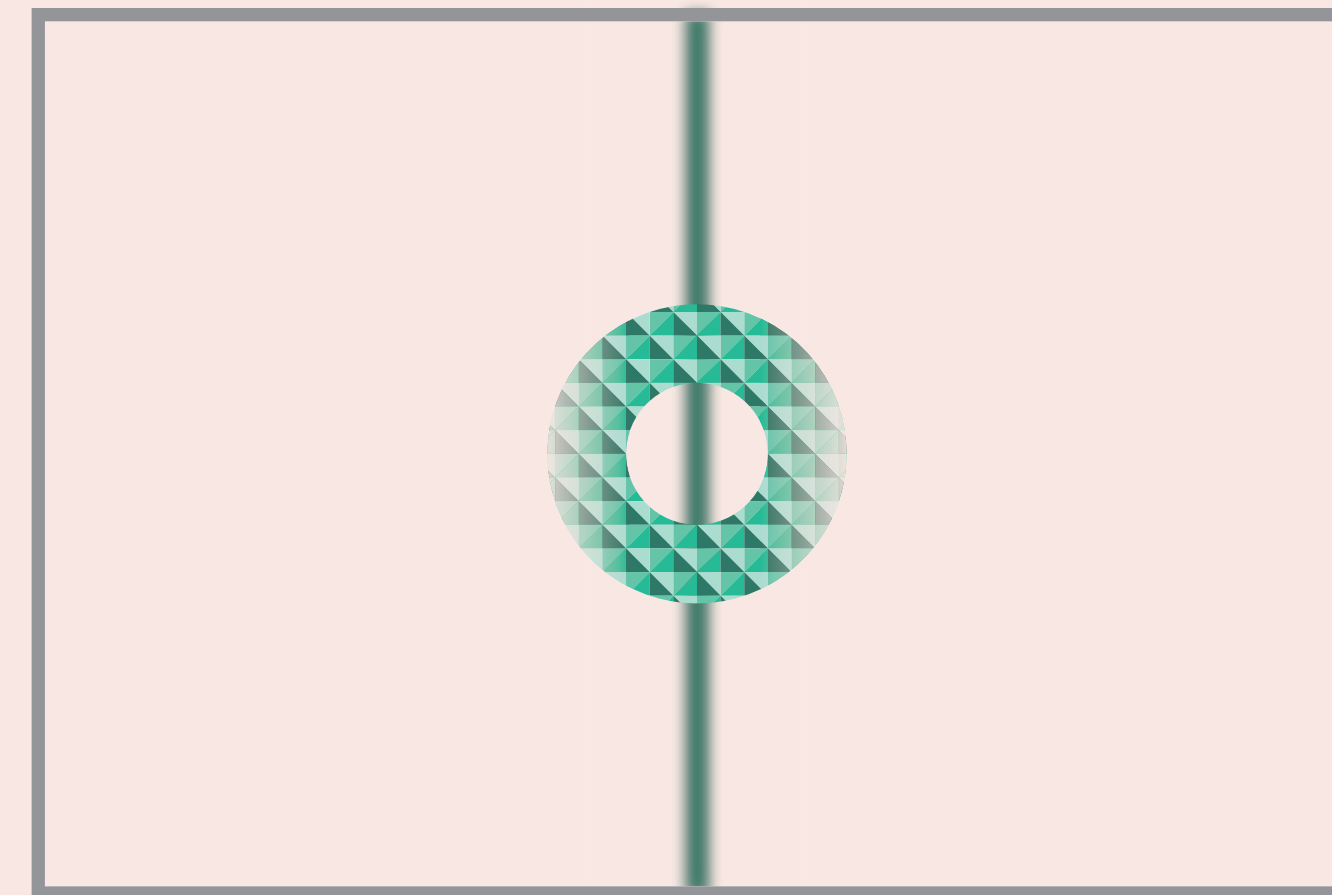
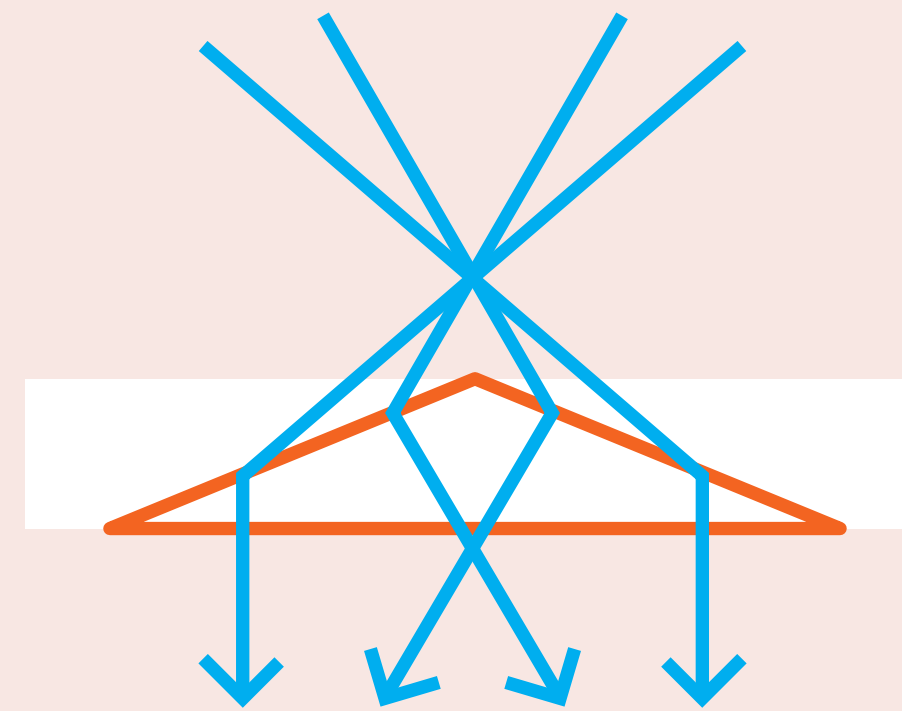

FOCADO

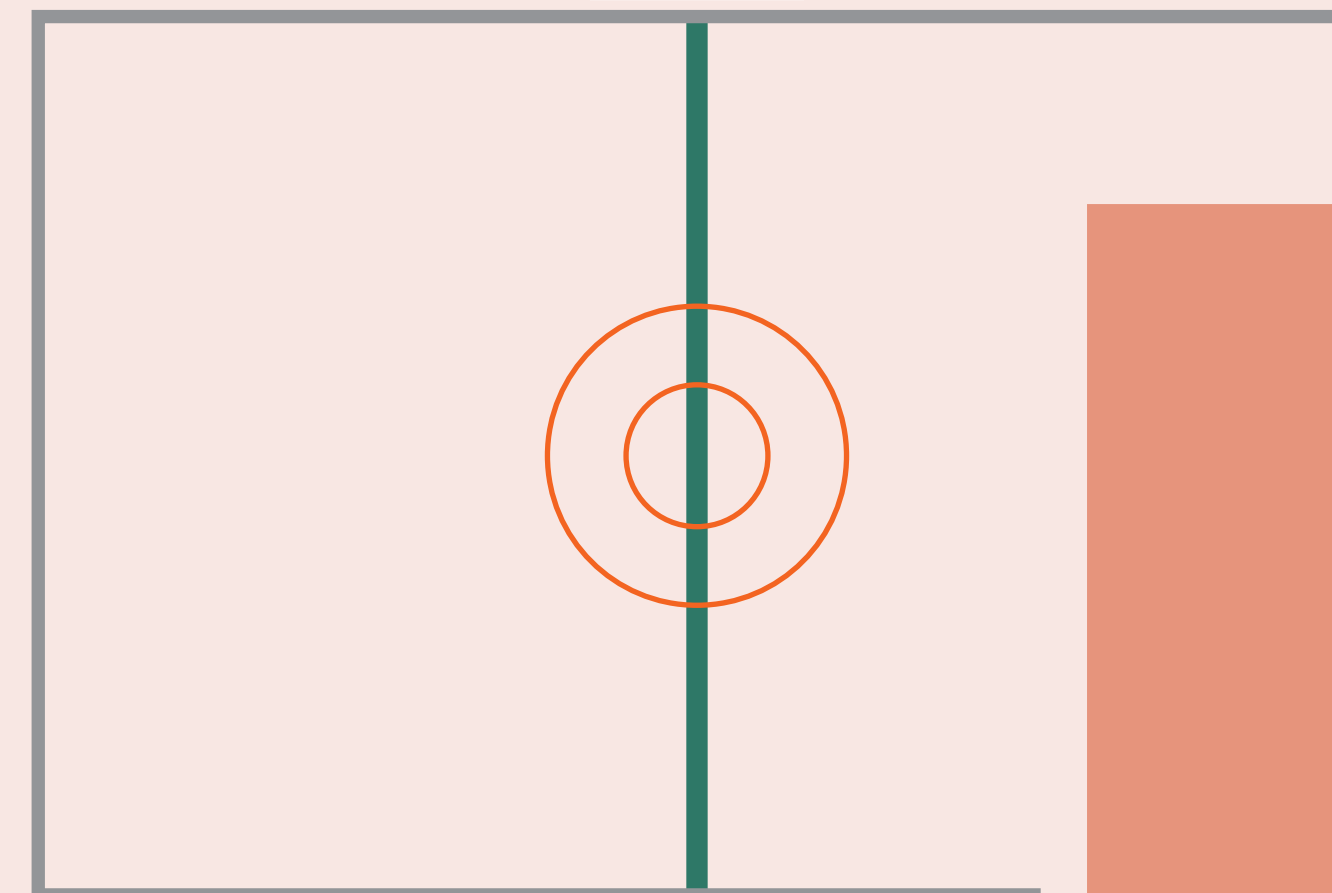
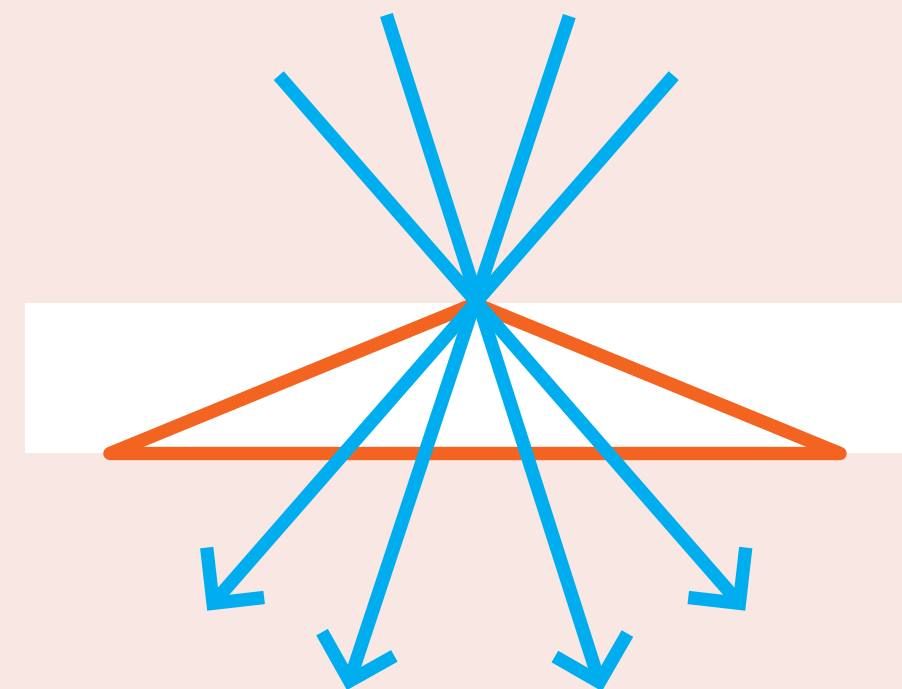

WEBCAM

PENTAPRISMA

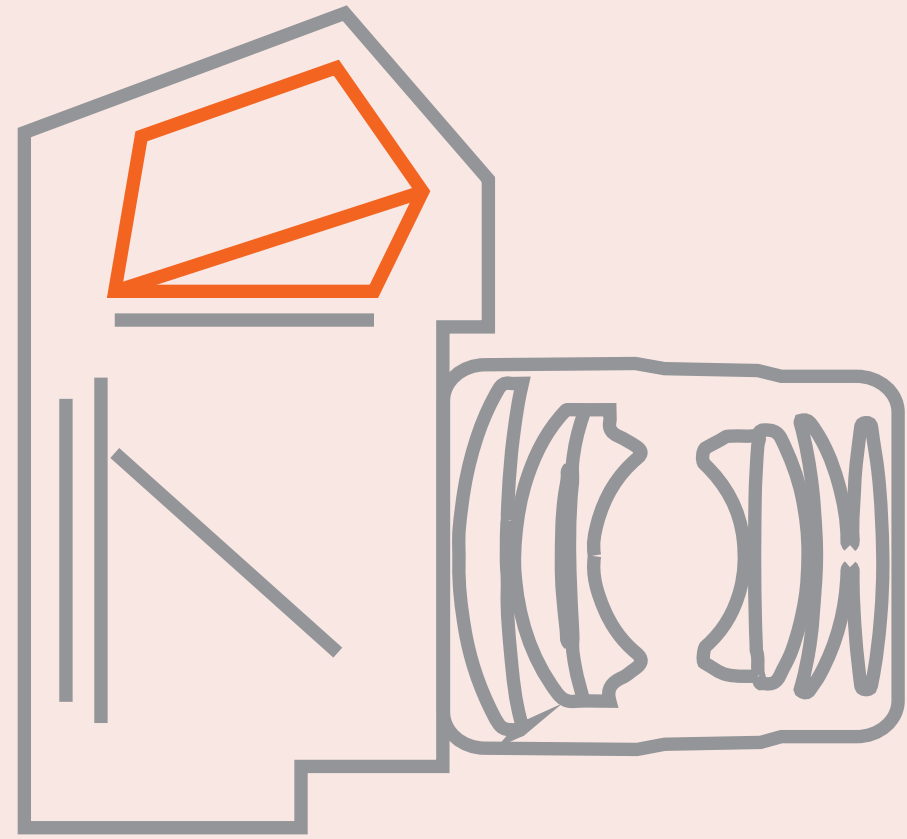

Fonte: Tian Cheng Optics Co.

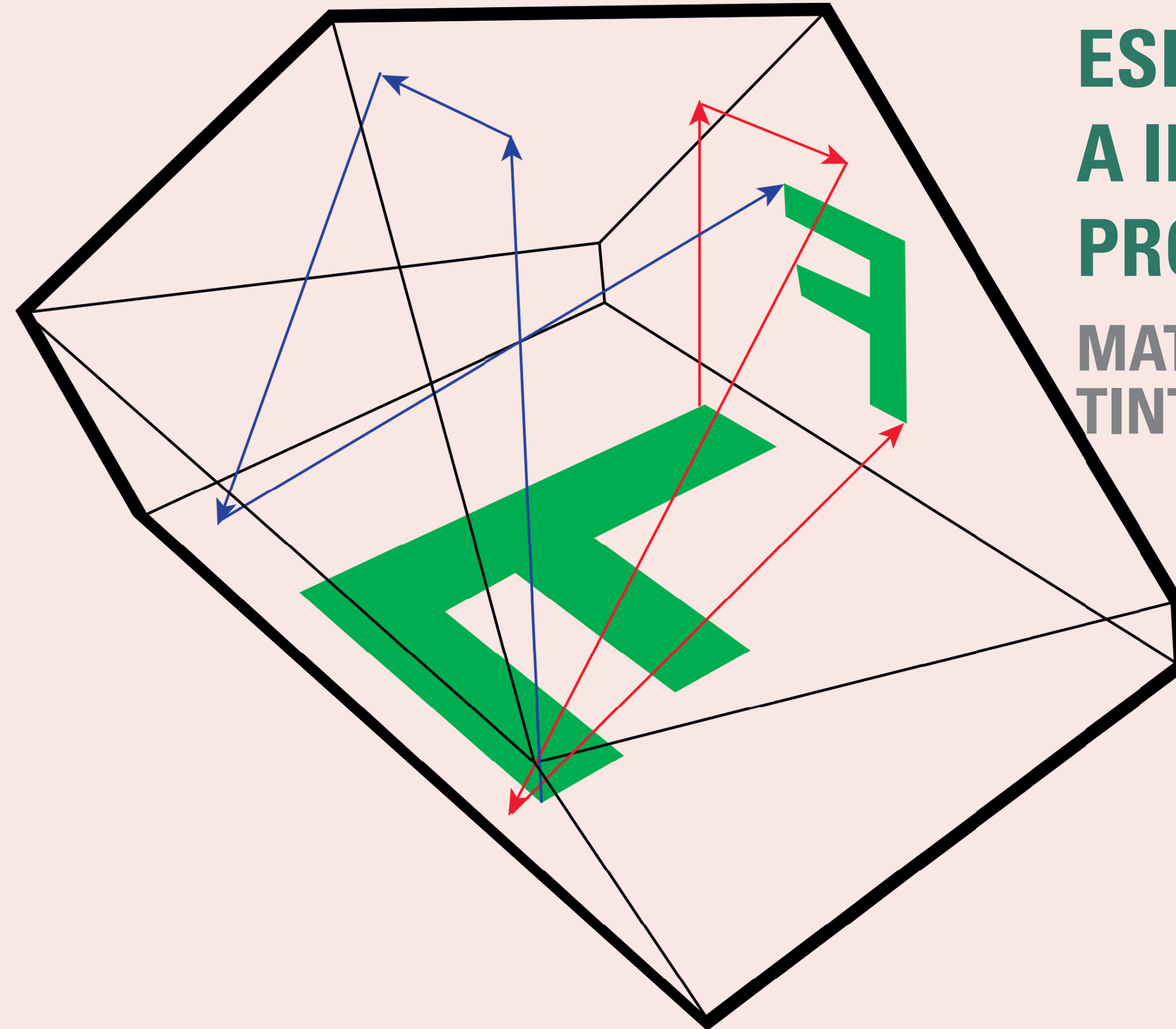

FUNÇÃO:
ESPELHAR HORIZONTALMENTE
A IMAGEM DO DESPOLIDO E
PROJETAR À 90° NO VISOR.

MATERIAL: CRISTAL ESPELHADO E
TINTA EPOXI PRETA.

WEBCAM

FUNIONAMENTO DA SLR

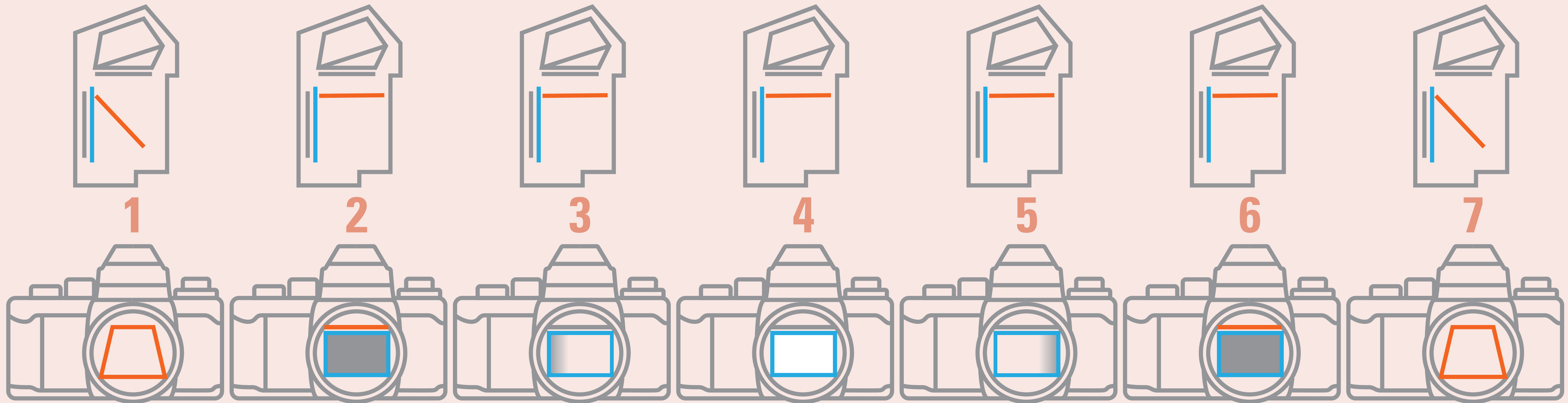

O ESPELHO SOBE

A PRIMEIRA PARTE
DO OBTURADOR ABRE

O FILME É
EXPOSTO

A SEGUNDA PARTE
DO OBTURADOR FECHA

WEBCAM

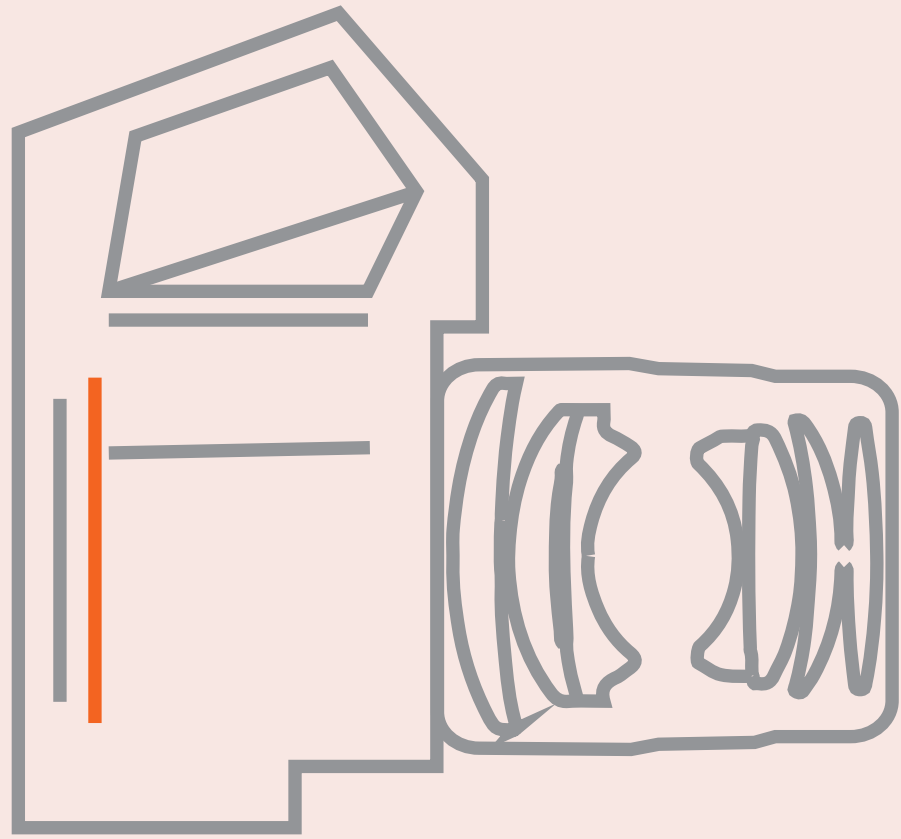

OBTURADOR



Fonte: Shutterstock

FUNÇÃO:
INICIAR E INTERROMPER, POR UM TEMPO DEFINIDO, A PROJEÇÃO DA IMAGEM NO FILME.

MATERIAL: TECIDO, METAL, PÁSTICO E ETC.

WEBCAM

OBTURADOR CORTINA



Fonte: Wikiwand

1

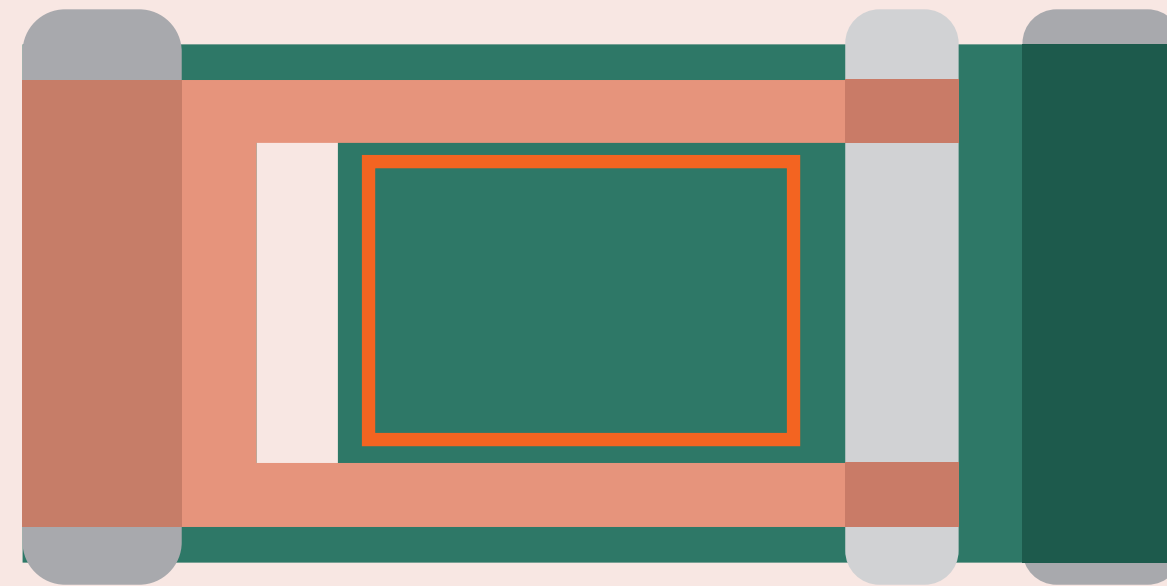

2

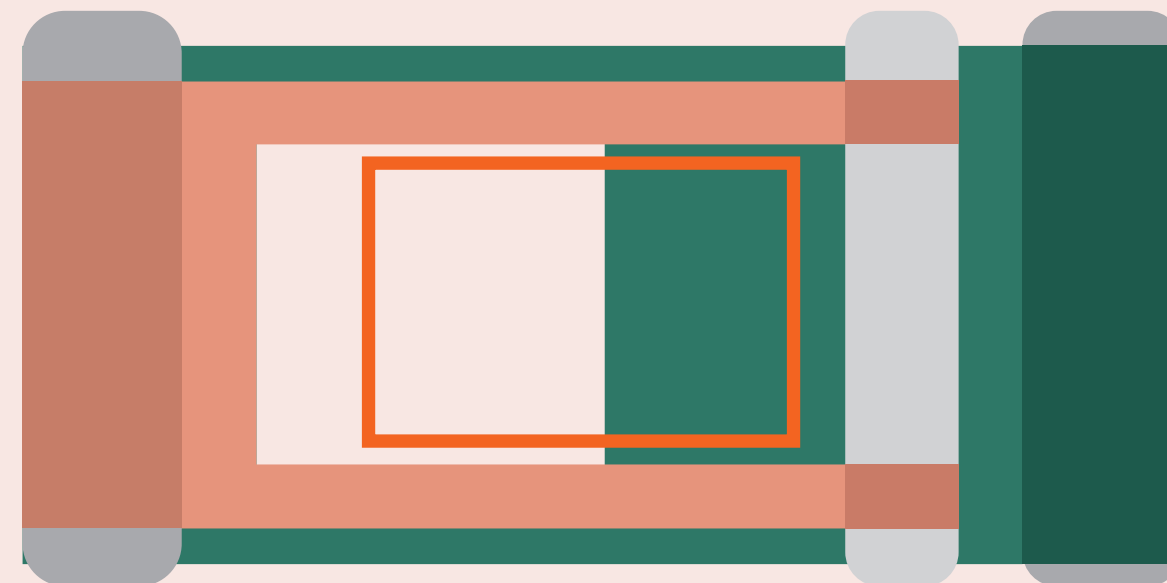

3

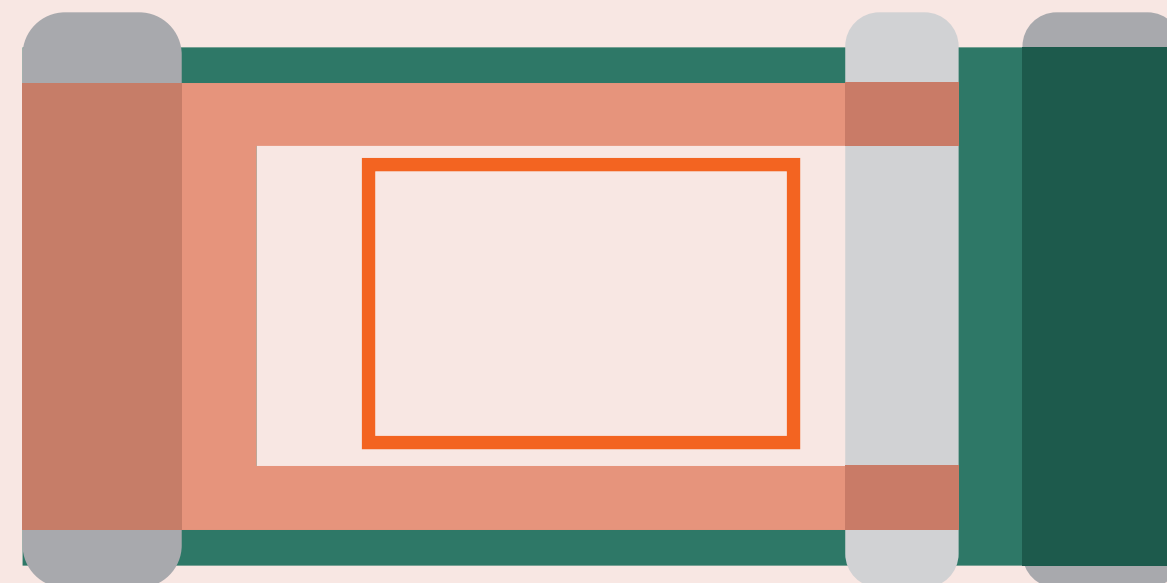

4

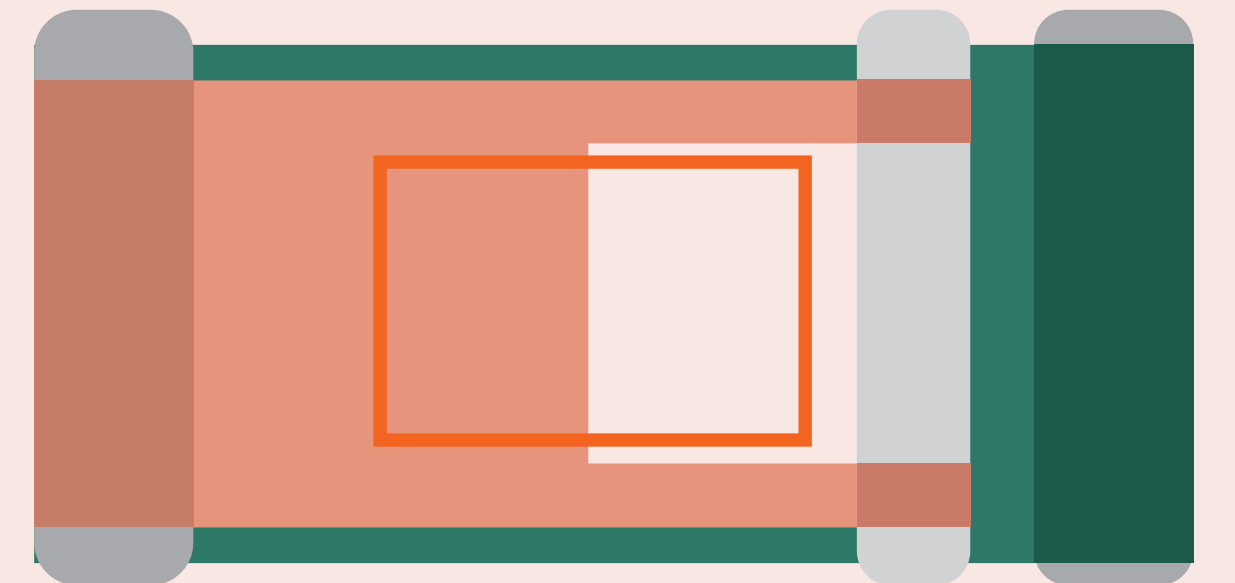

5

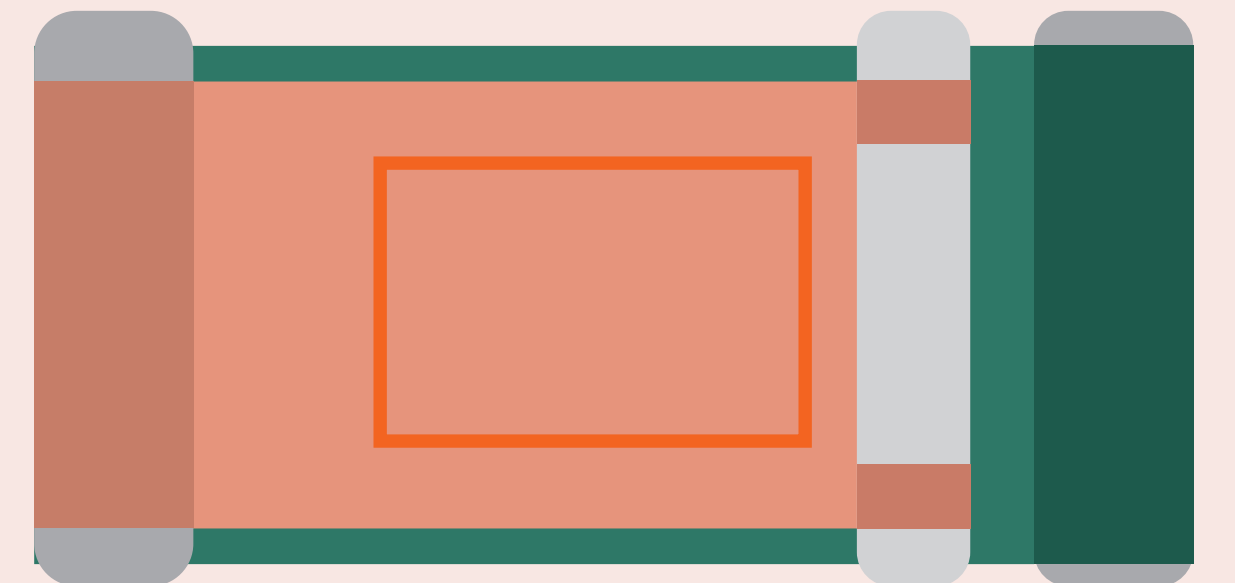

WEBCAM

OBTURADOR DE PÁS

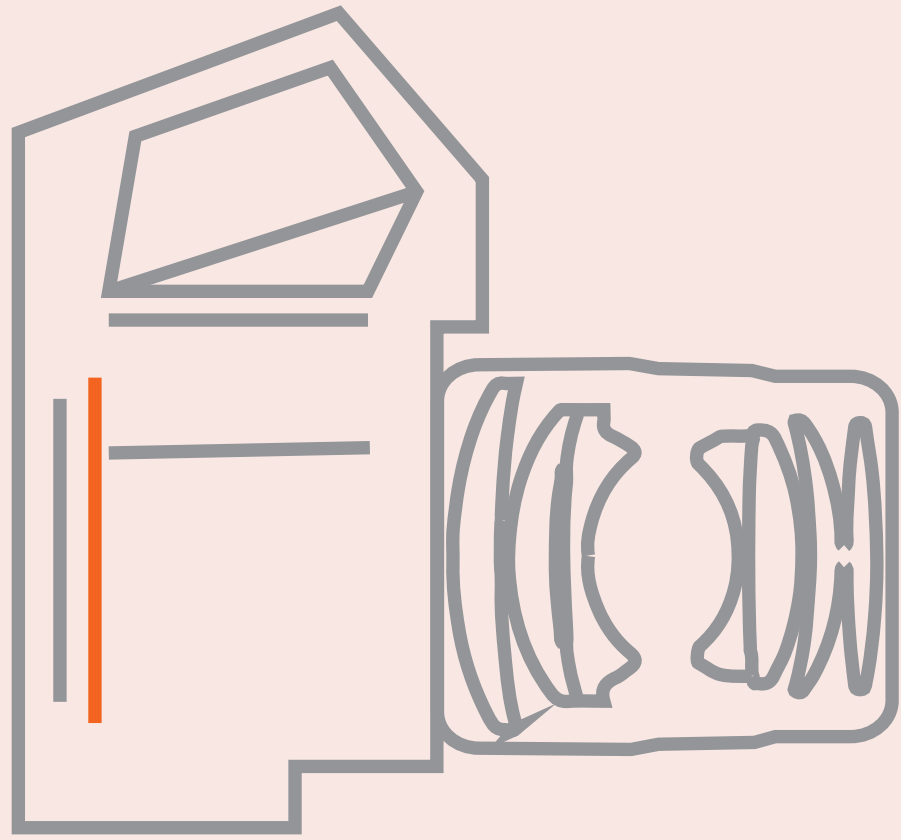

Fonte: Ebay

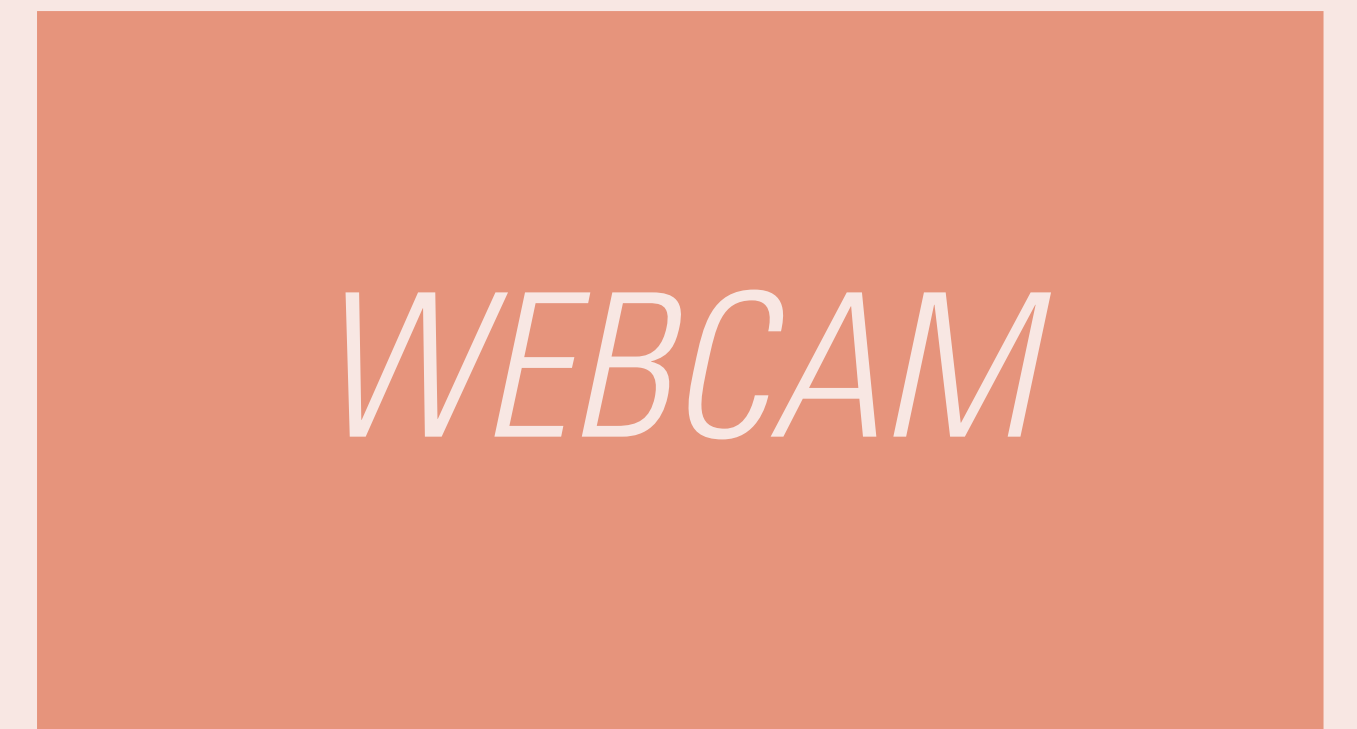
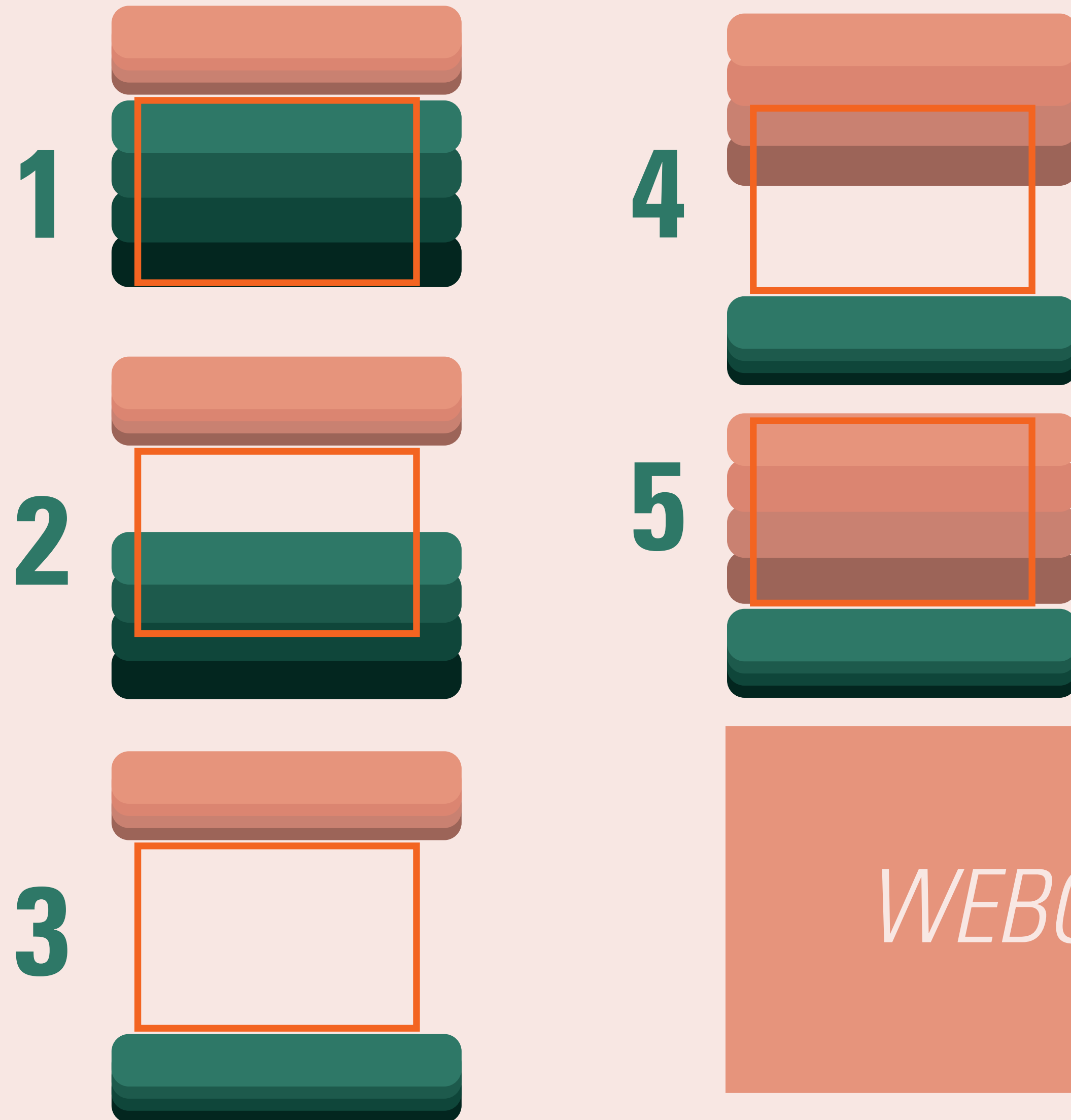

TIPOS DE CÂMERA PEQUENO FORMATO VISOR DIRETO



WEBCAM

TIPOS DE CÂMERA PEQUENO FORMATO

VISOR DIRETO

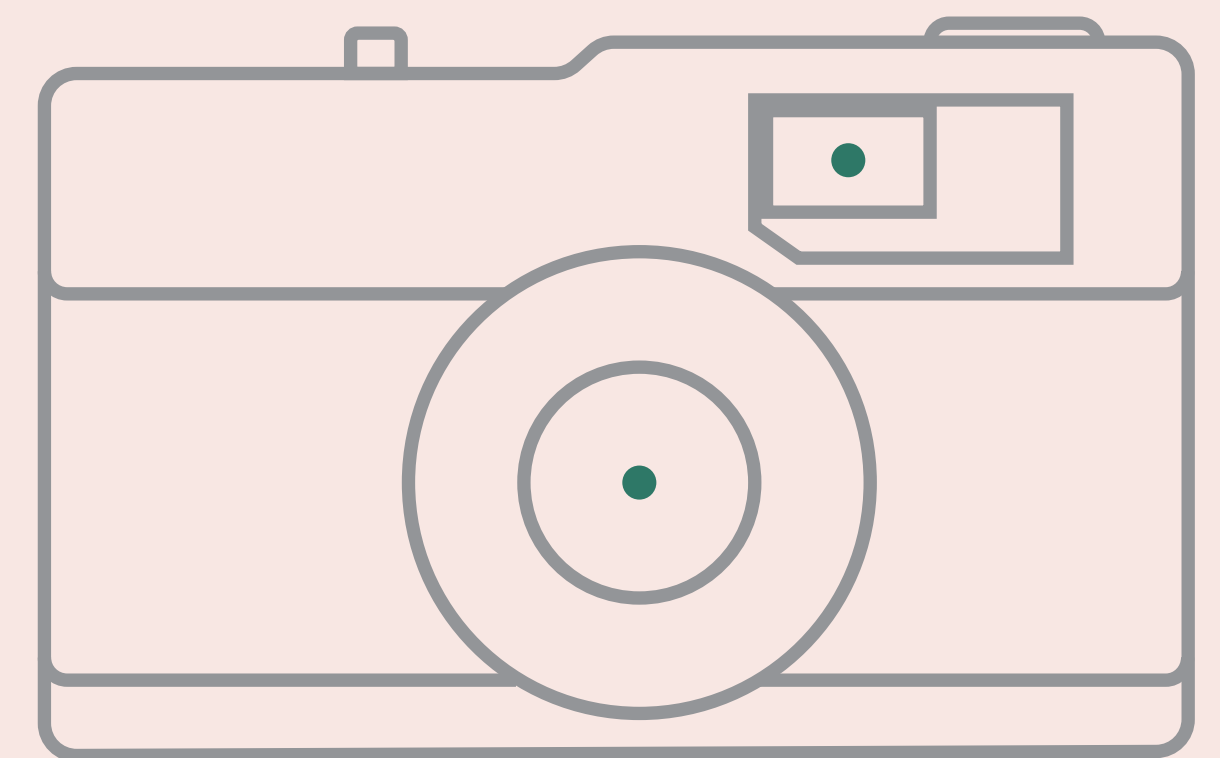
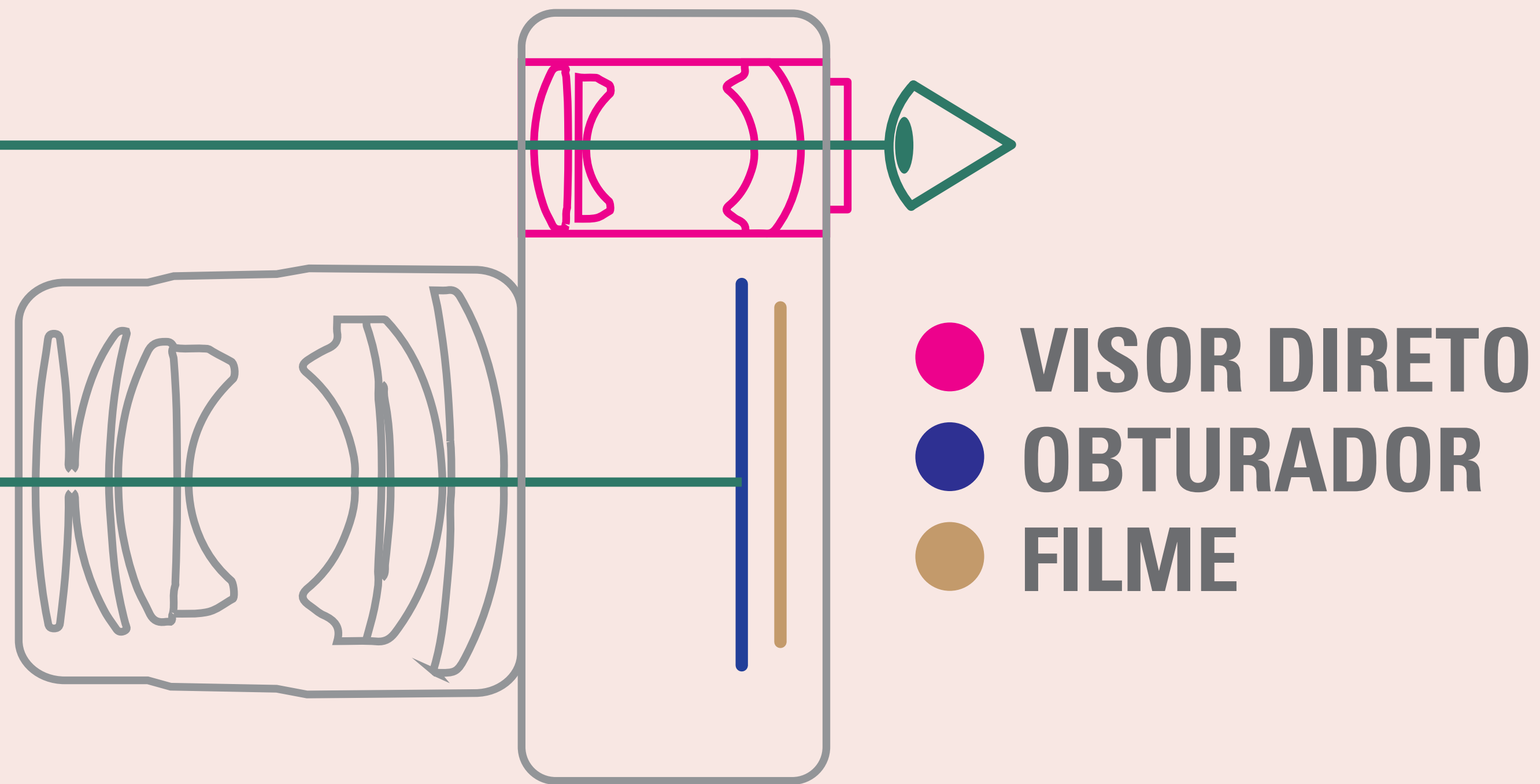

WEBCAM

TIPOS DE CÂMERA PEQUENO FORMATO

RANGE FINDER



WEBCAM

TIPOS DE CÂMERA PEQUENO FORMATO

RANGE FINDER

TELÊMETRO

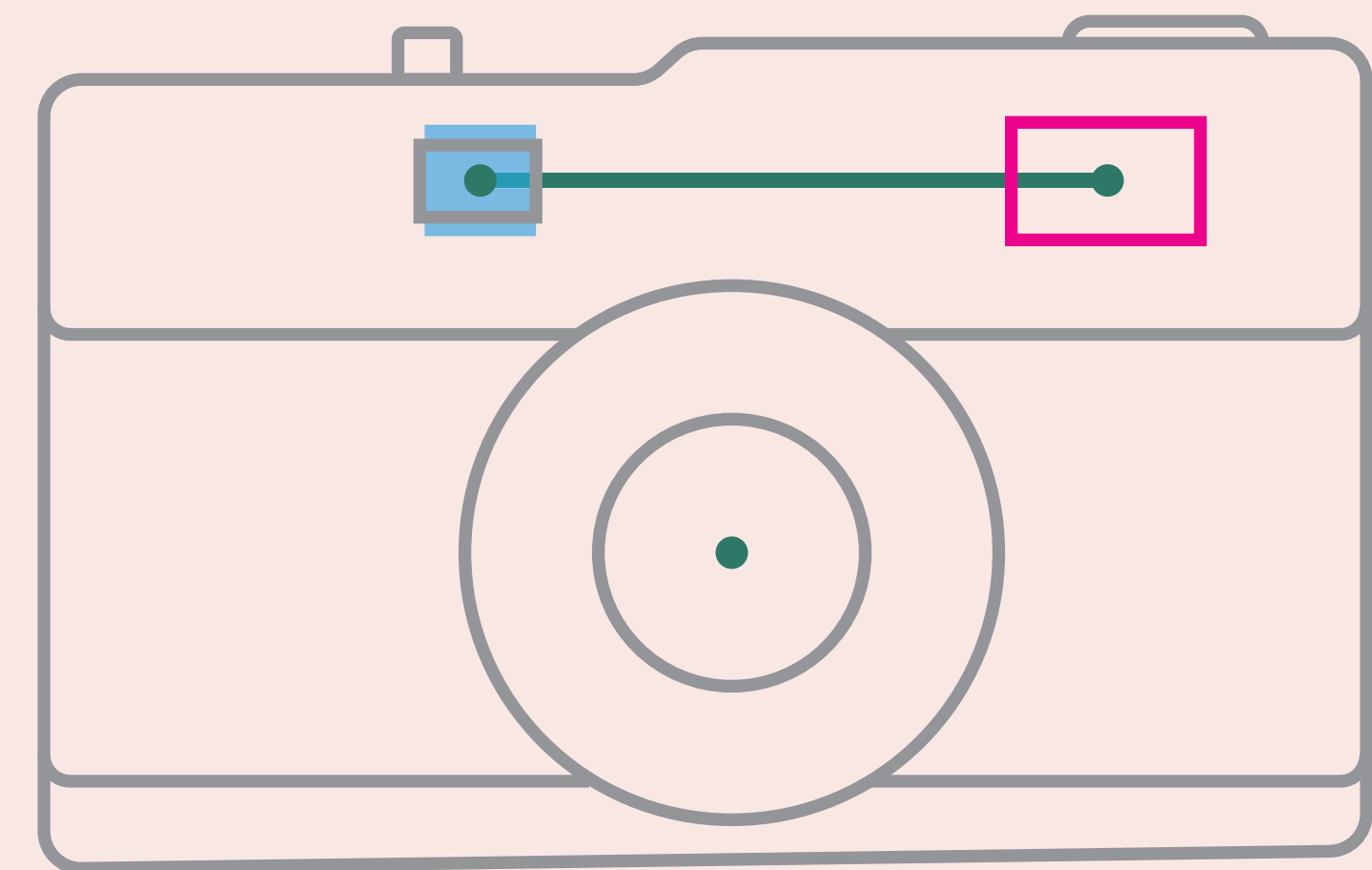
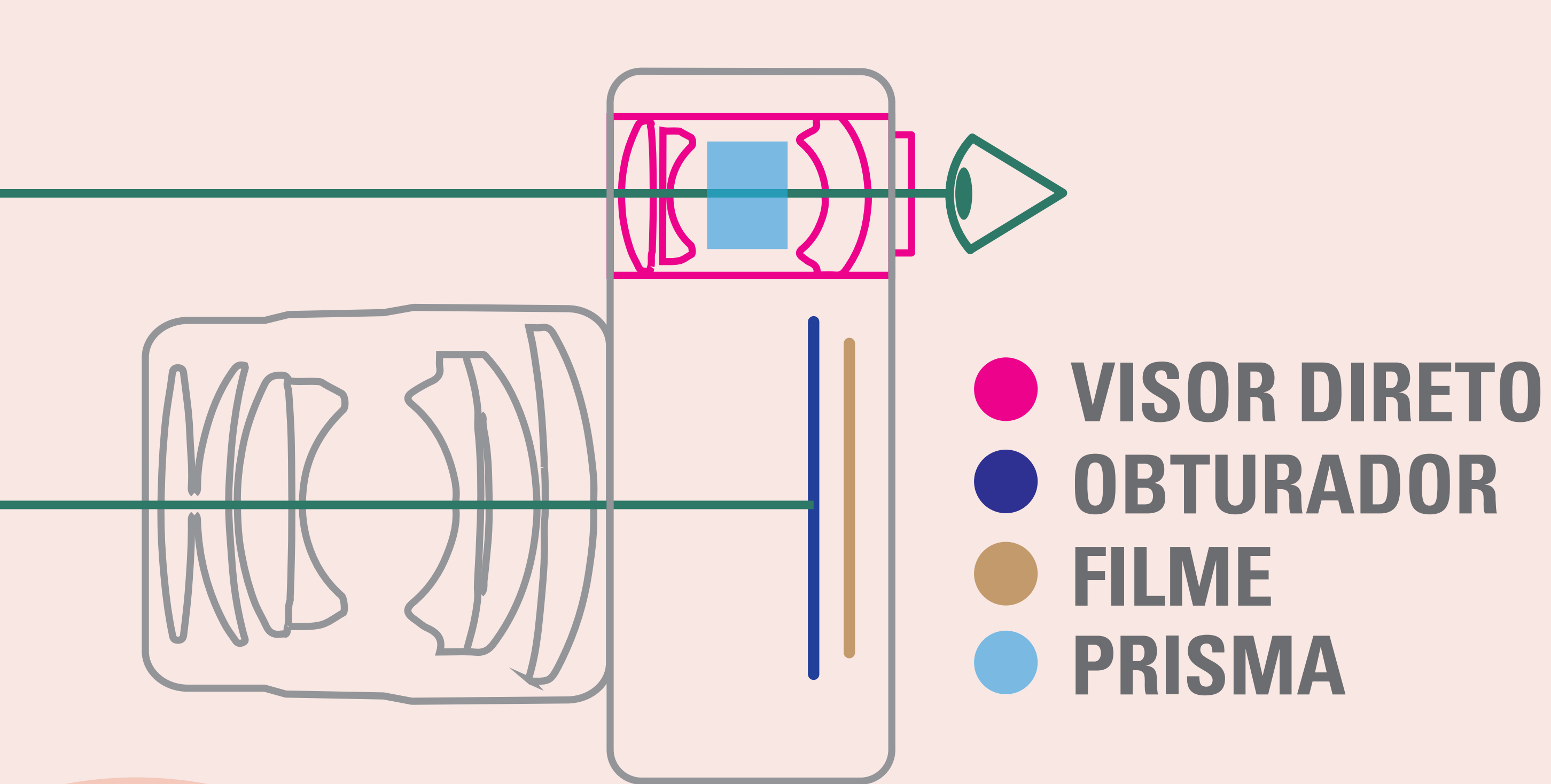

WEBCAM

FOCAGEM POR TELÊMETRO

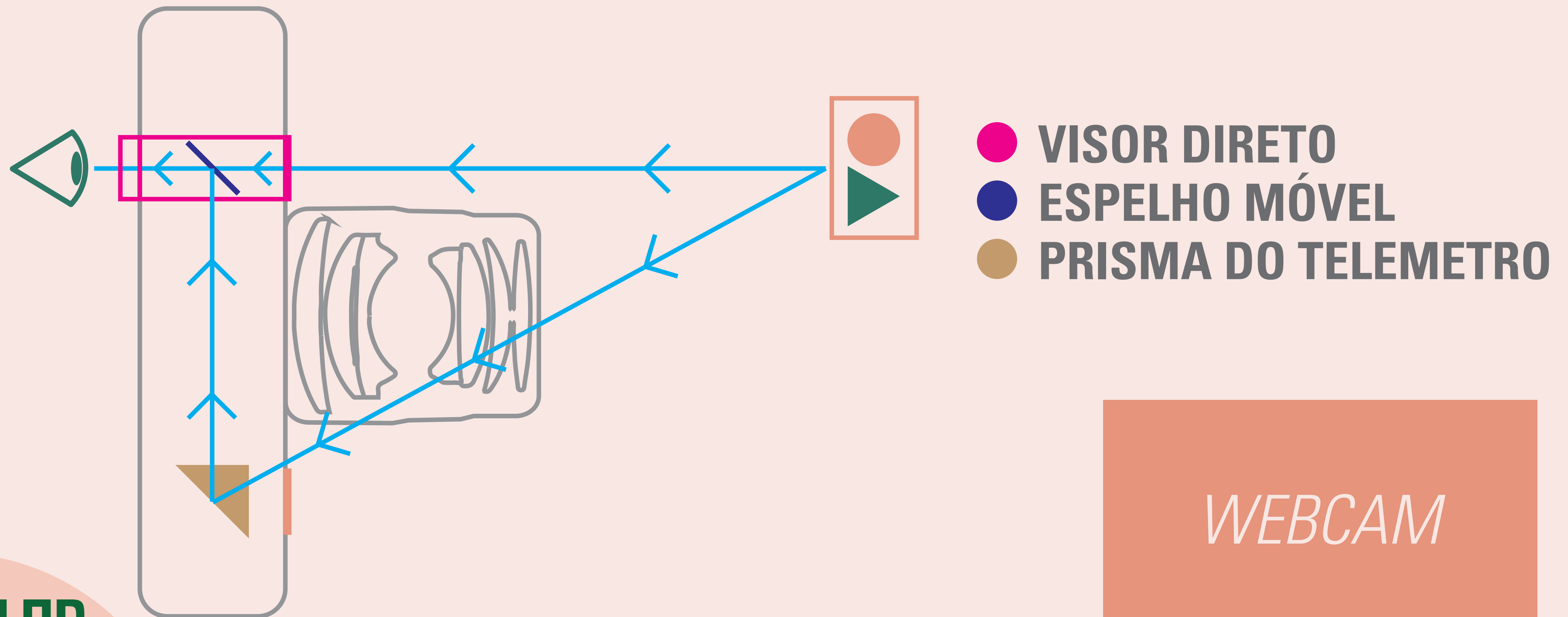

FOCAGEM POR TELÊMETRO

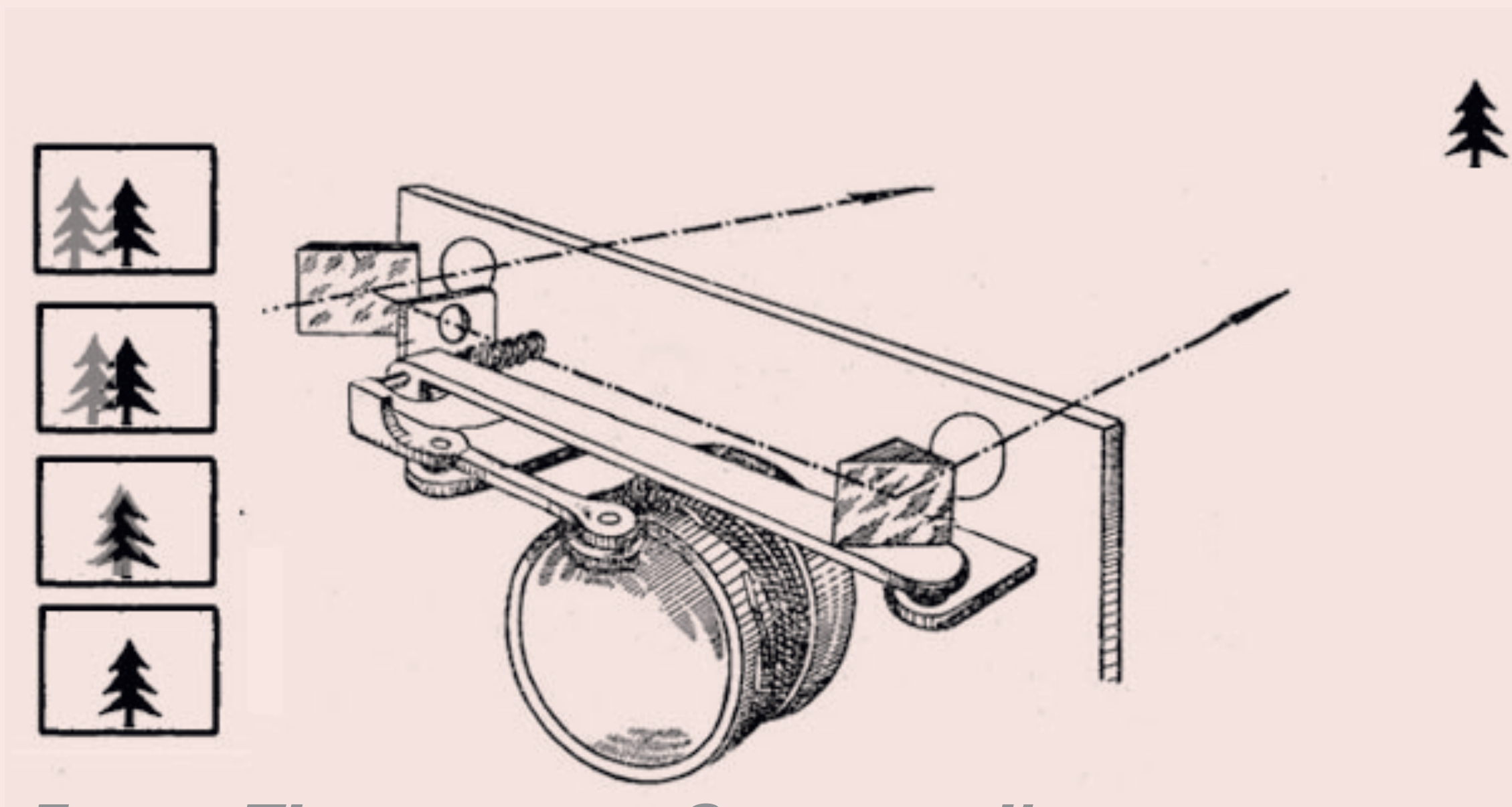

Fonte: Thorsten von Overgaard'

DESFOCADO

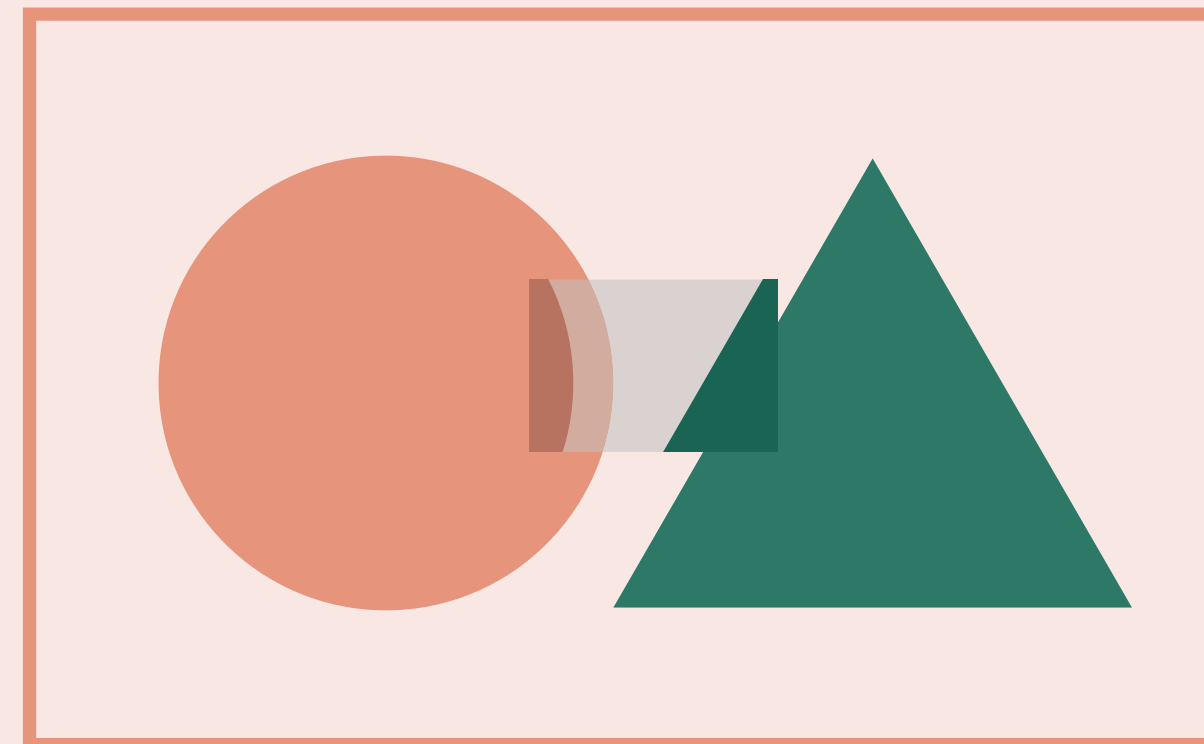

FOCADO

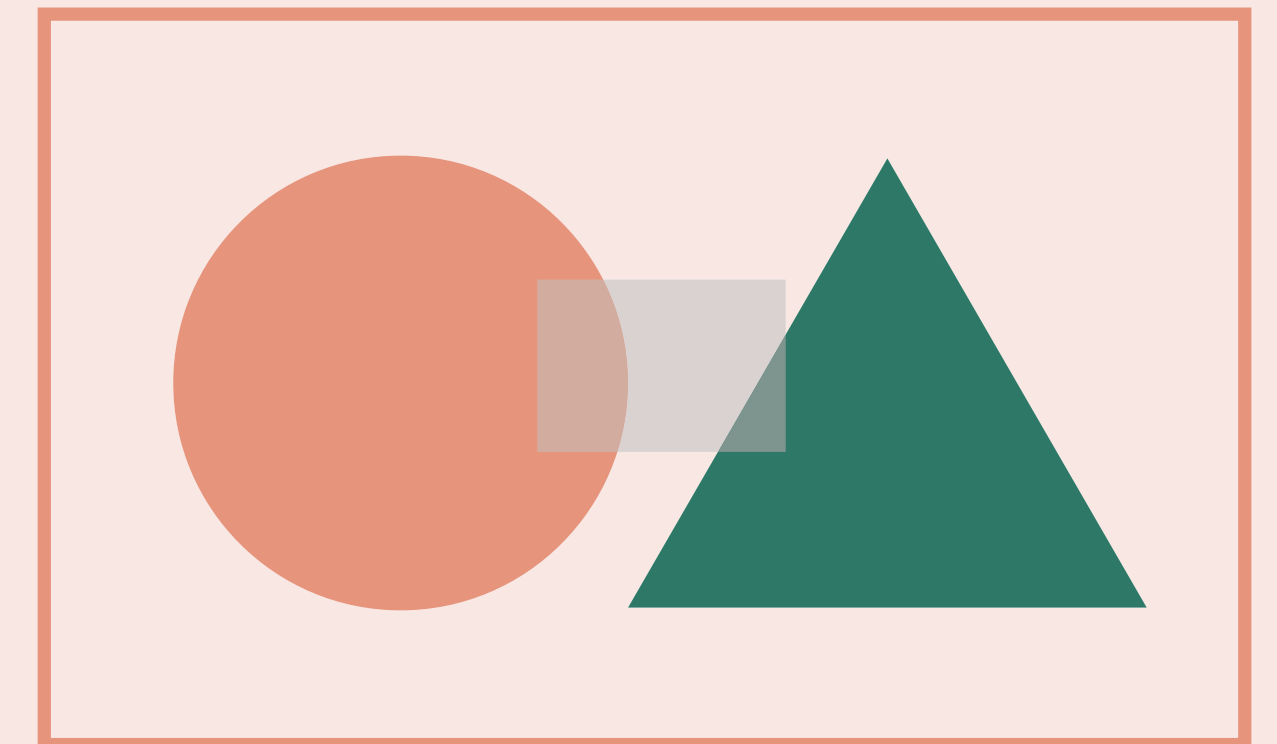

WEBCAM

TIPOS DE CÂMERA MÉDIO FORMATO

TLR - TWIN LENS REFLEX

REFLEXÍVEL DE LENTE DUPLA



WEBCAM

TIPOS DE CÂMERA MÉDIO FORMATO

TLR - TWIN LENS REFLEX

REFLEXÍVEL DE LENTE DUPLA

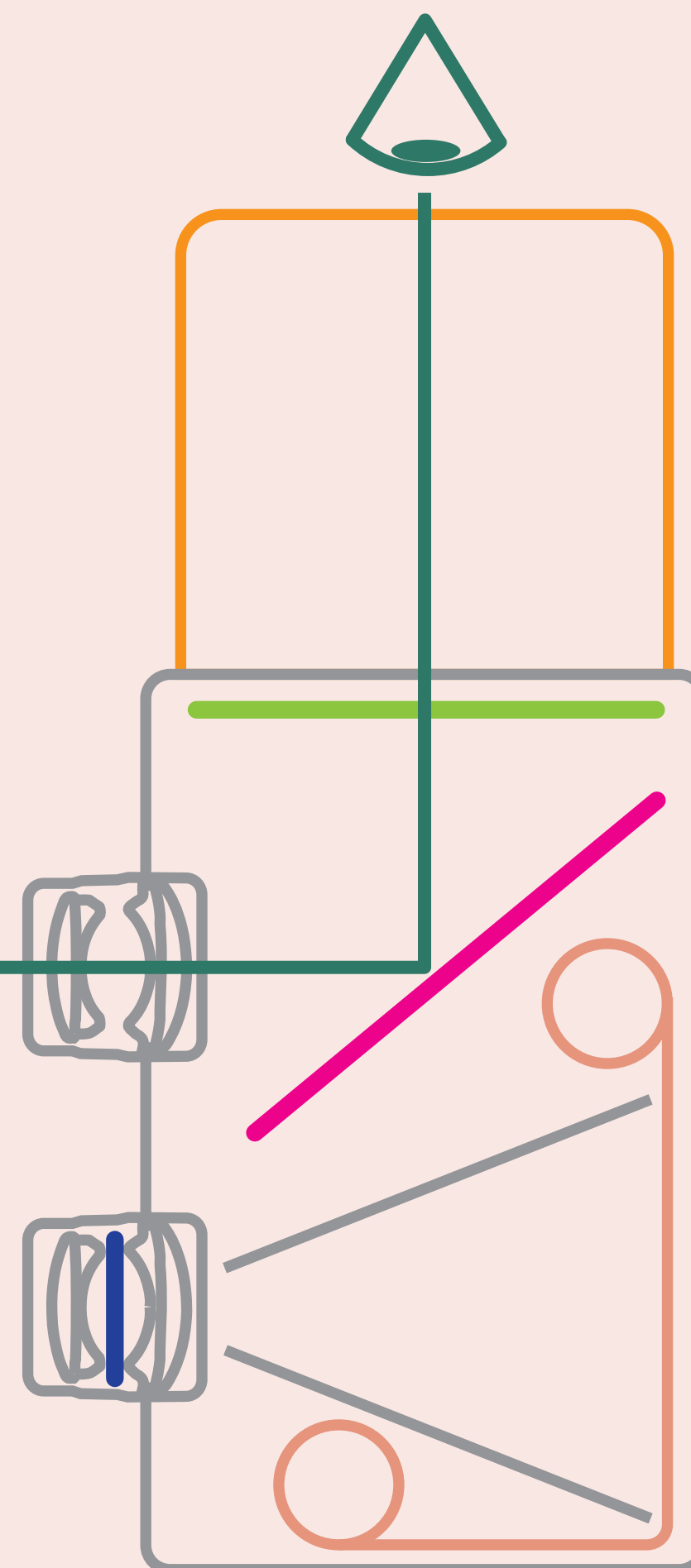

- CAPUCHÃO
- ESPELHO
- OBTURADOR
- FILME
- DESPOLIDO ou TELA DE FOCAGEM

WEBCAM

OBTURADOR DE PÁS

1



2

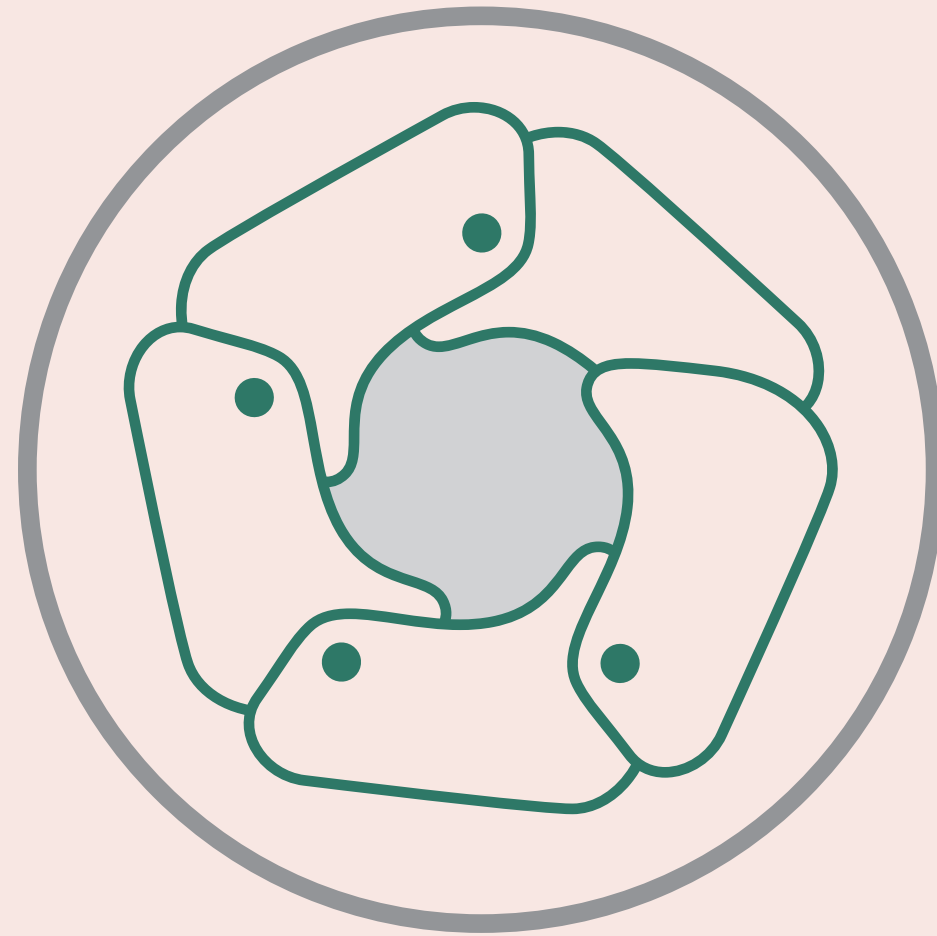

3

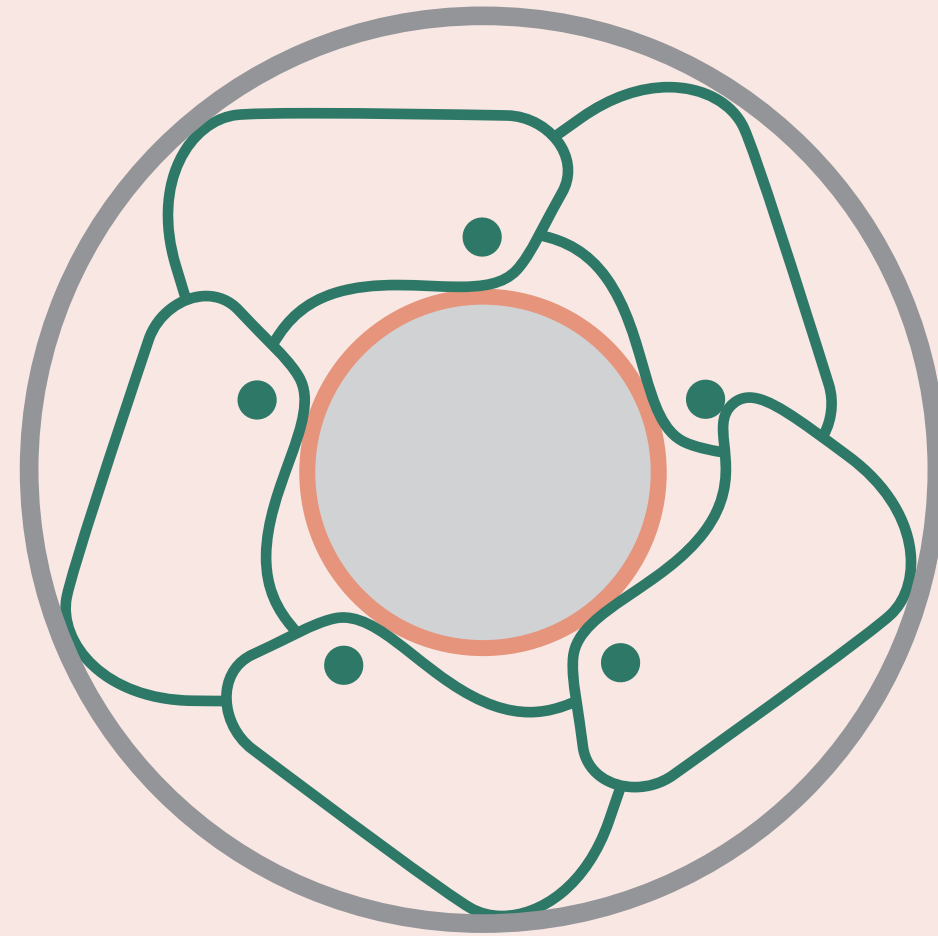

4

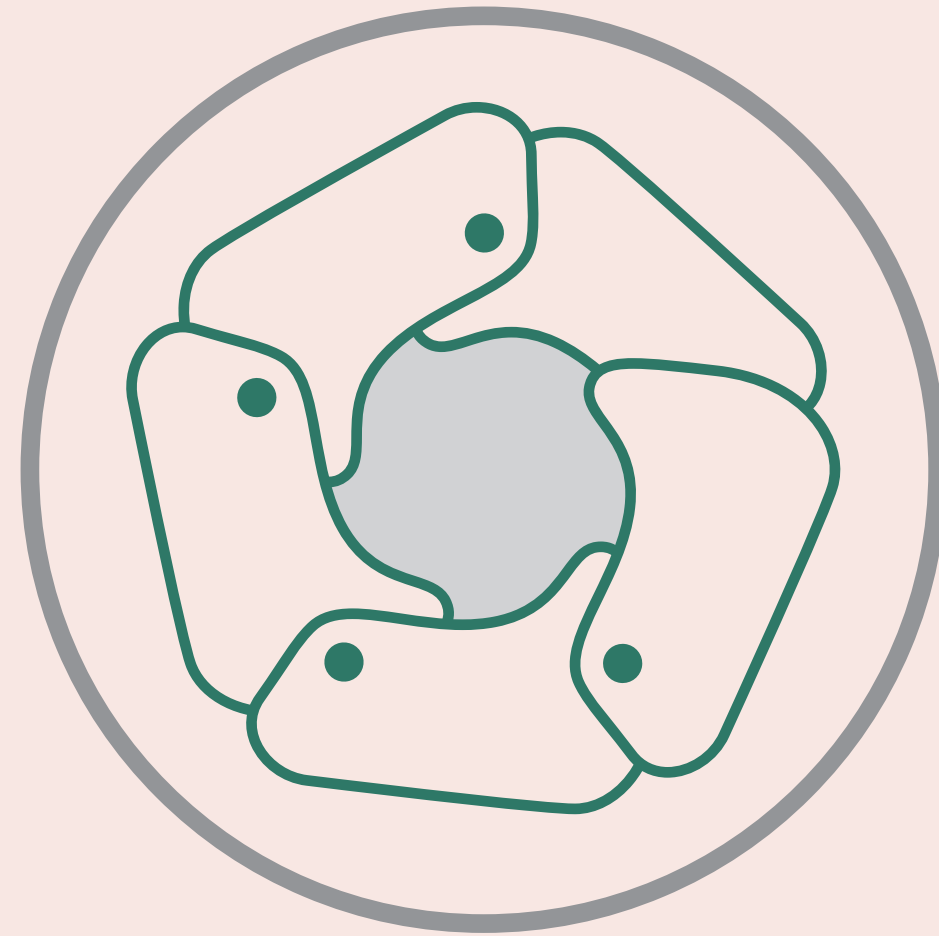

5

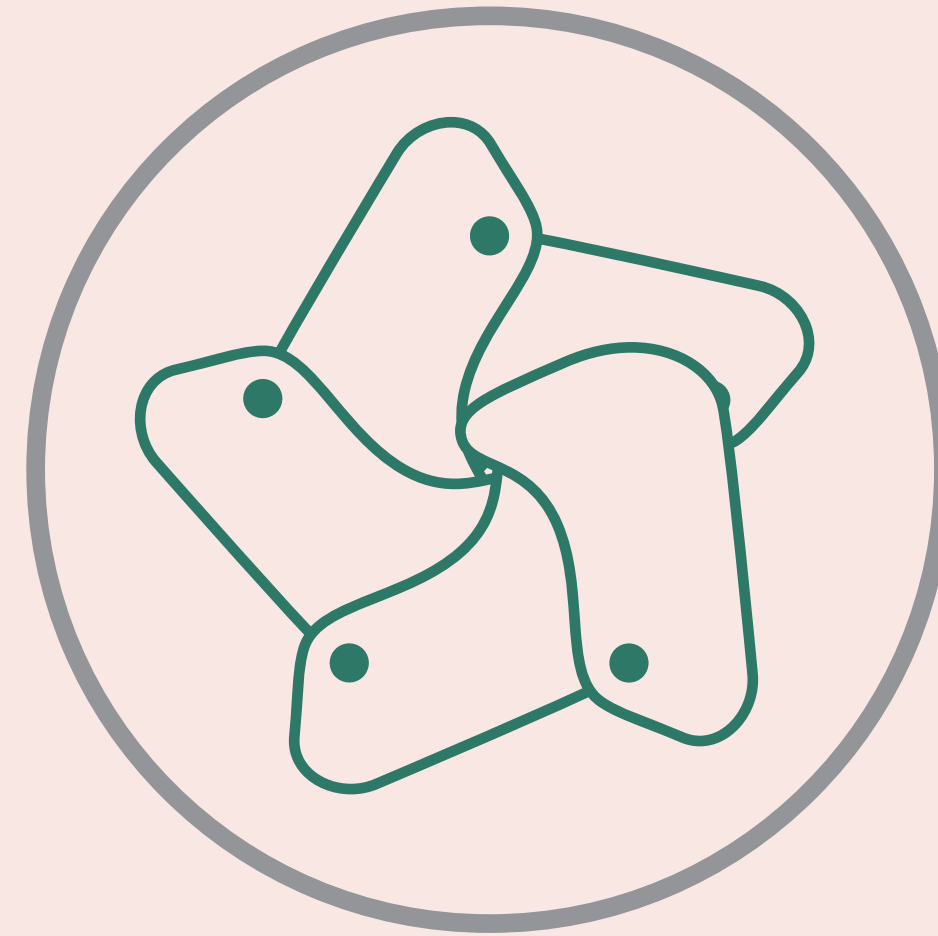

WEBCAM

TIPOS DE CÂMERA MÉDIO FORMATO
SLR - SINGLE LENS REFLEX
REFLEXÍVEL DE LENTE SIMPLES



WEBCAM

TIPOS DE CÂMERA MÉDIO FORMATO

SLR - SINGLE LENS REFLEX

REFLEXÍVEL DE LENTE SIMPLES

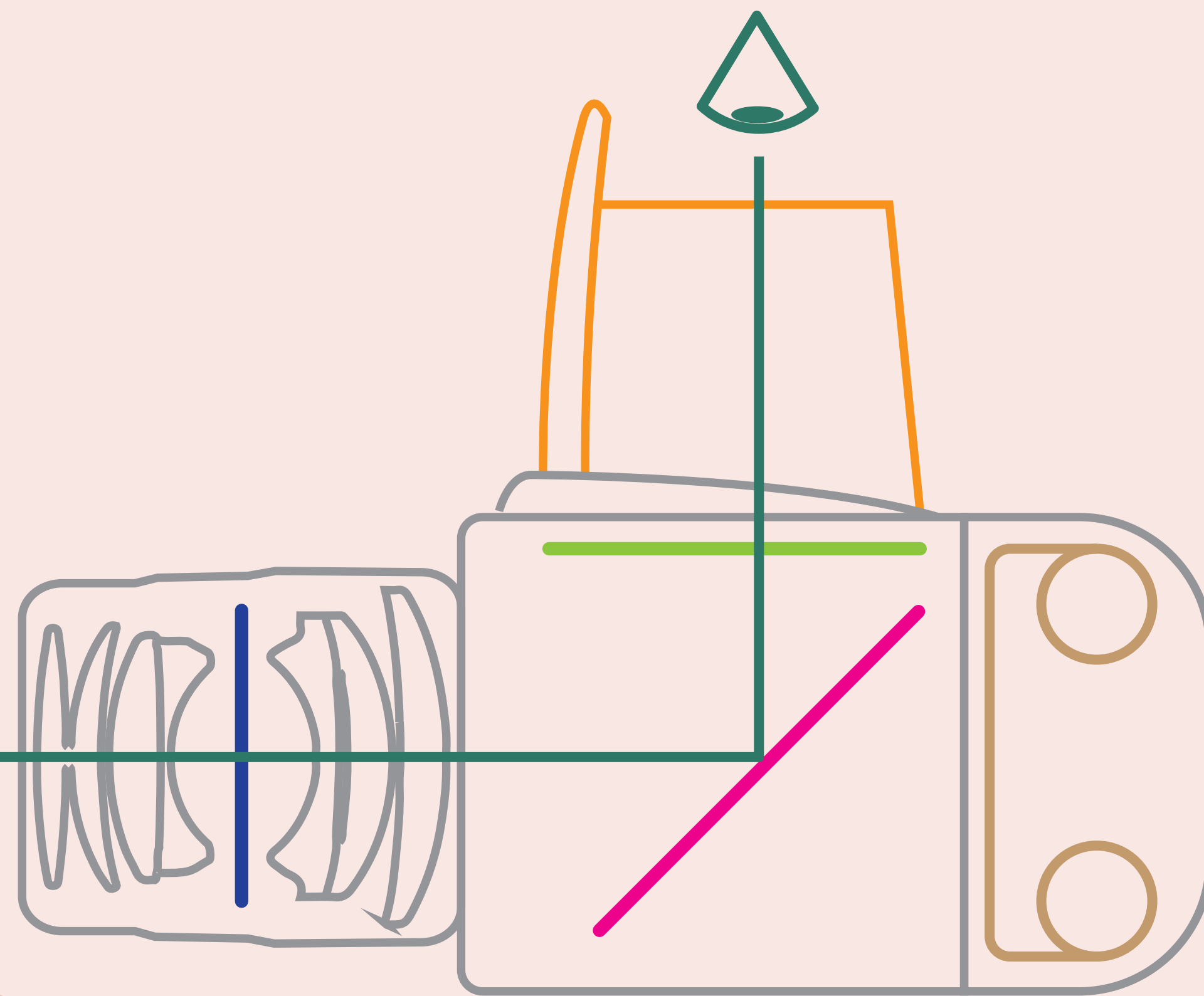

- CAPUÇÃO
- ESPELHO
- OBTURADOR
- FILME
- DESPOLIDO ou TELA DE FOCAGEM

WEBCAM

TIPOS DE CÂMERA MÉDIO FORMATO

SLR - SINGLE LENS REFLEX

REFLEXÍVEL DE LENTE SIMPLES



WEBCAM

TIPOS DE CÂMERA MÉDIO FORMATO

RANGE FINDER DE FOLE

TELÊMETRO

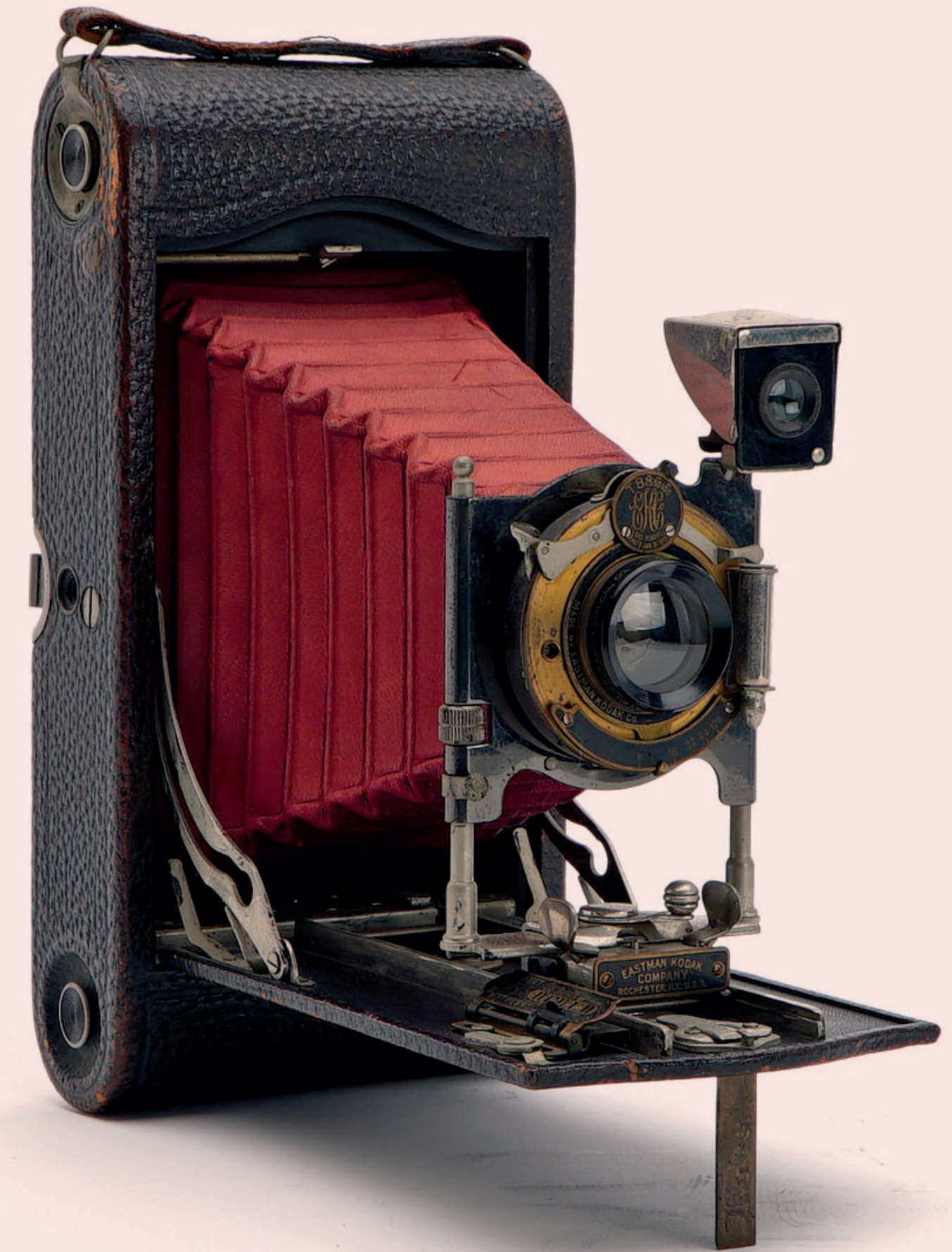

WEBCAM

TIPOS DE CÂMERA MÉDIO FORMATO

RANGE FINDER DE FOLE

TELÊMETRO

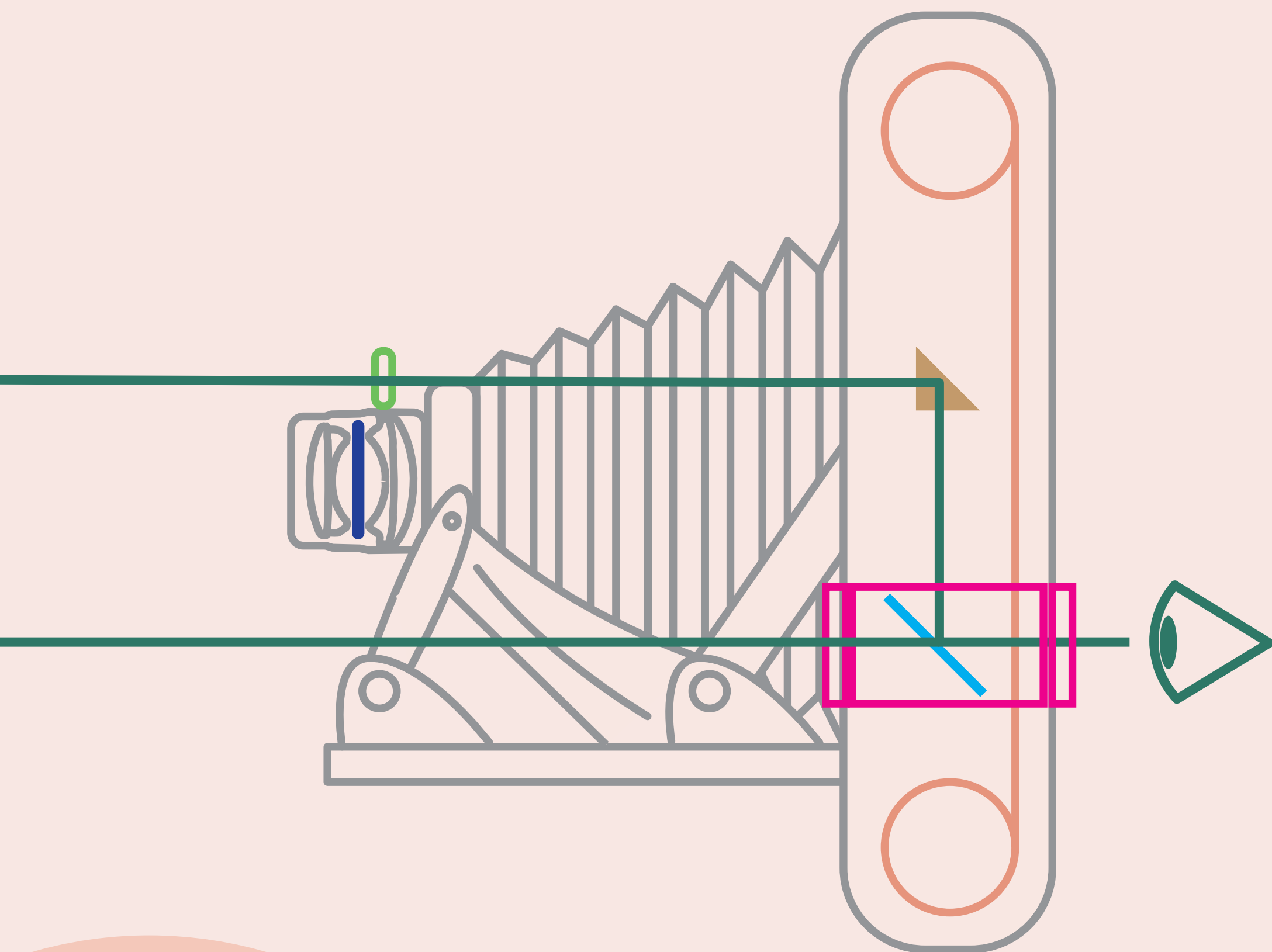

- LENTE DO TELÊMETRO
- VISOR DIRETO
- ESPELHO
- PRISMA DO TELEMETRO
- OBTURADOR
- FILME

WEBCAM

TIPOS DE CÂMERA MÉDIO FORMATO VISOR DIRETO "CAIXOTE"



WEBCAM

TIPOS DE CÂMERA MÉDIO FORMATO

VISOR DIRETO "CAIXOTE"

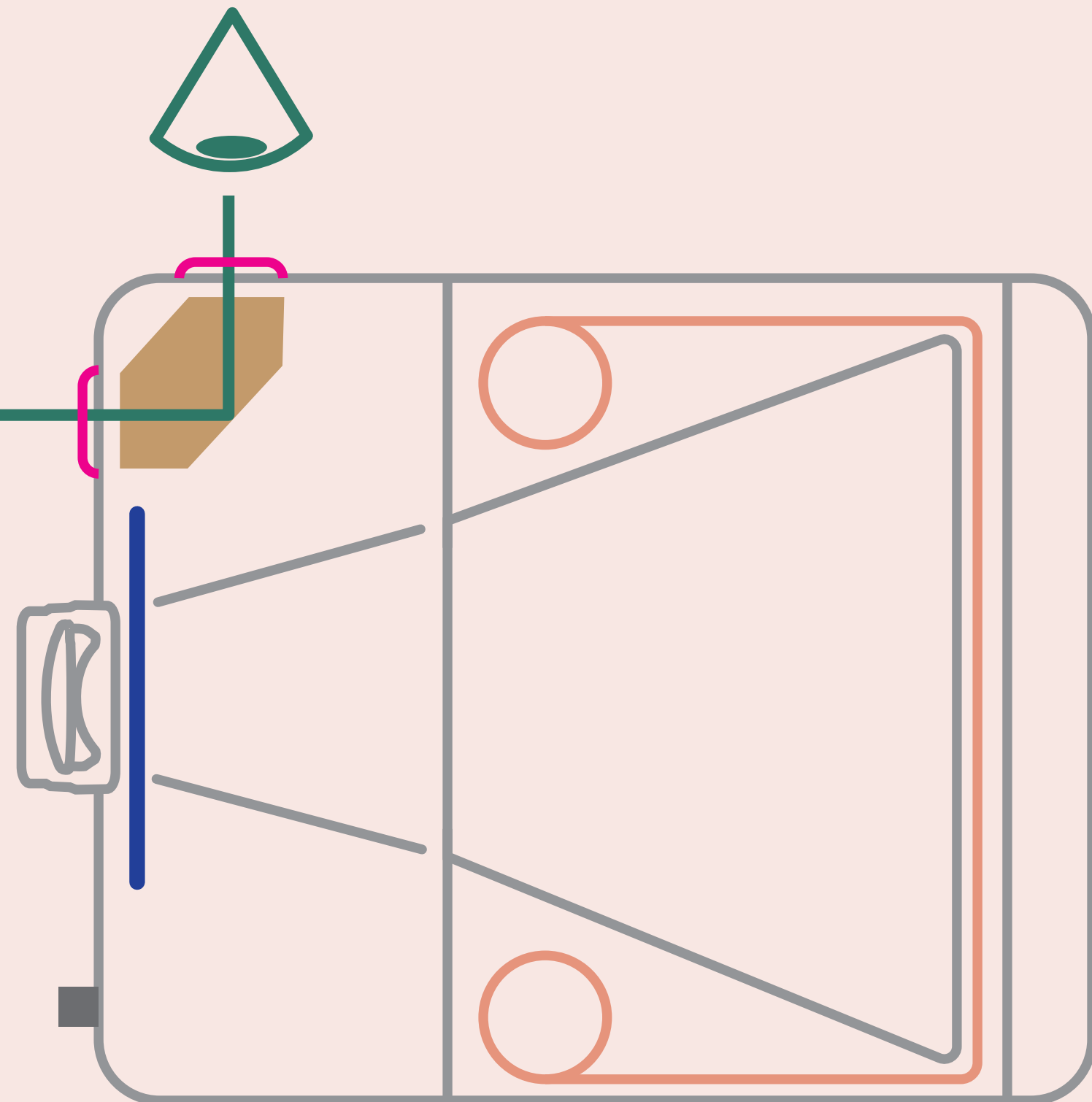

- VISOR DIRETO
- OBTURADOR
- PRISMA
- FILME

WEBCAM

TIPOS DE CÂMERA GRANDE FORMATO TRADICIONAL



Fonte: Studio Binders



© www.alexbond.com.au



© KenRockwell.com

Fonte: Ken Rockwell

WEBCAM

TIPOS DE CÂMERA GRANDE FORMATO **TRADICIONAL**

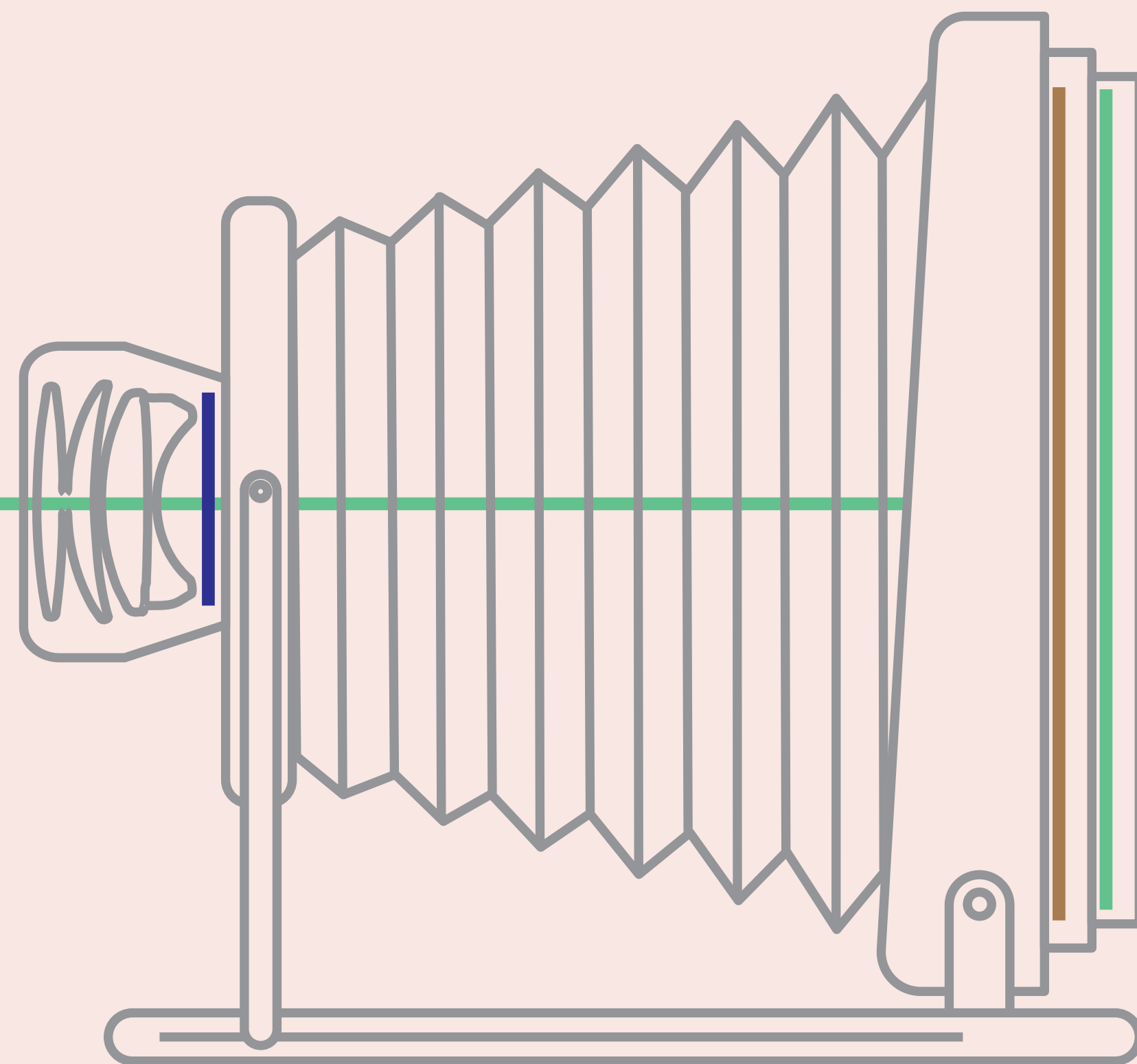

- **OBTURADOR**
- **MAGAZINE COM FILME**
- **DESPOLIDO**

WEBCAM

CÂMERA GRANDE FORMATO TRADICIONAL FOCAGEM



WEBCAM

Fonte: Standard Cameras

CÂMERA GRANDE FORMATO TRADICIONAL MAGAZINE E FILME



WEBCAM

CÂMERA GRANDE FORMATO TRADICIONAL CARREGAMENTO



WEBCAM

CABÔ, VALEU.

Conteúdo e ilustrações: Vitor Lopes Leite / Lab:Lab Analógico

Apresentado em 29 de Julho de 2021 no Youtube.

Confira em: <https://www.youtube.com/watch?v=GT4JtbVcBaY>

LAB:LAB
ANALÓGICO

***www.lablab.com.br
[instagram.com/lab.lab_br](https://www.instagram.com/lab.lab_br)
[youtube.com/c/lablabanalogico](https://www.youtube.com/c/lablabanalogico)***

CC BY-NC-SA
Atribuição-NãoComercial-Compartilhalgual

