

CURSO GRATUITO LAB:LAB

FOTOGRAFIA ANALÓGICA

C O M P L E T A

AULA 03

A LENTE

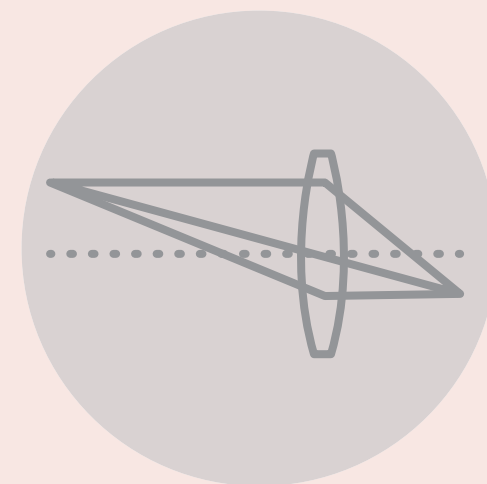
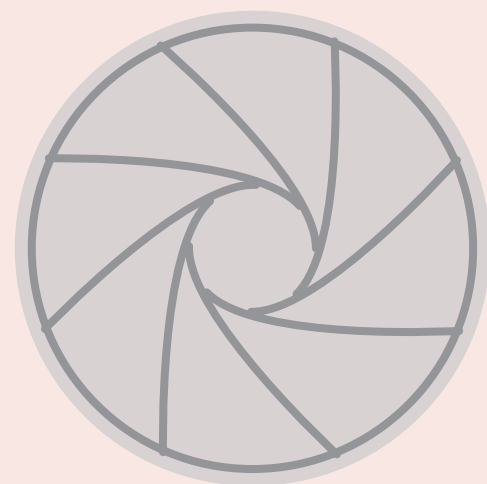
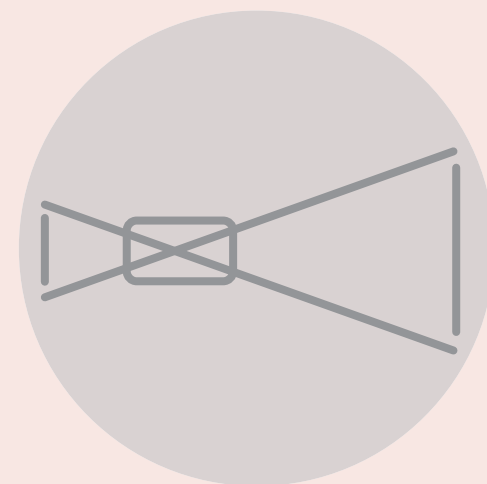
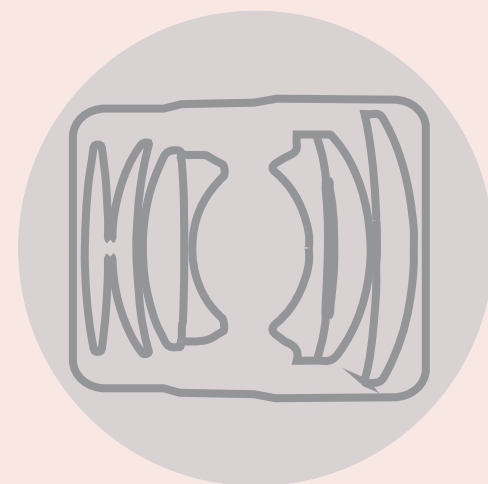

WEBCAM

CENA E PROJEÇÃO

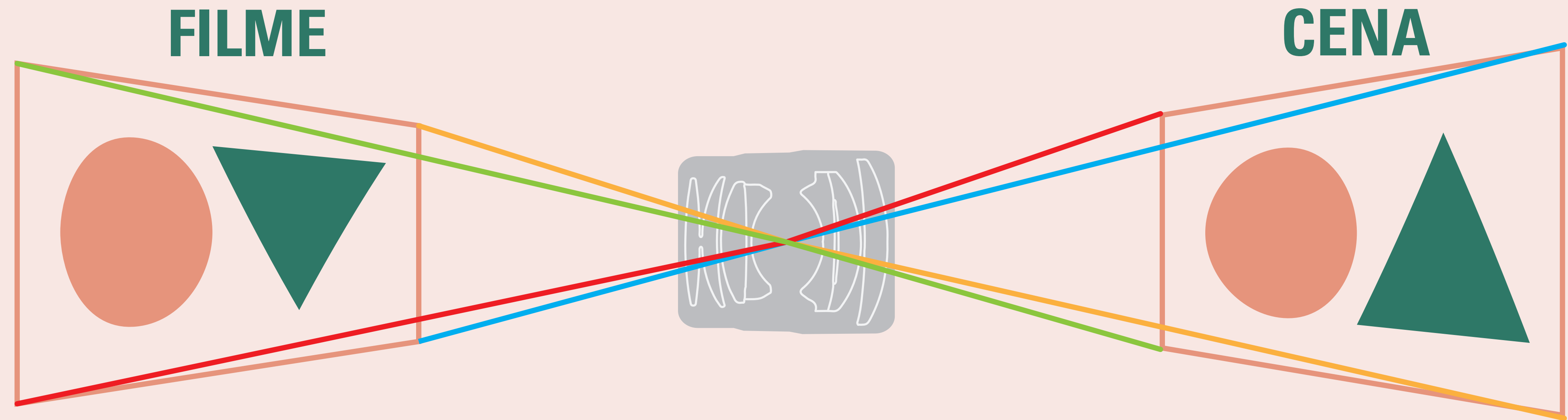

WEBCAM

CENA E PROJEÇÃO

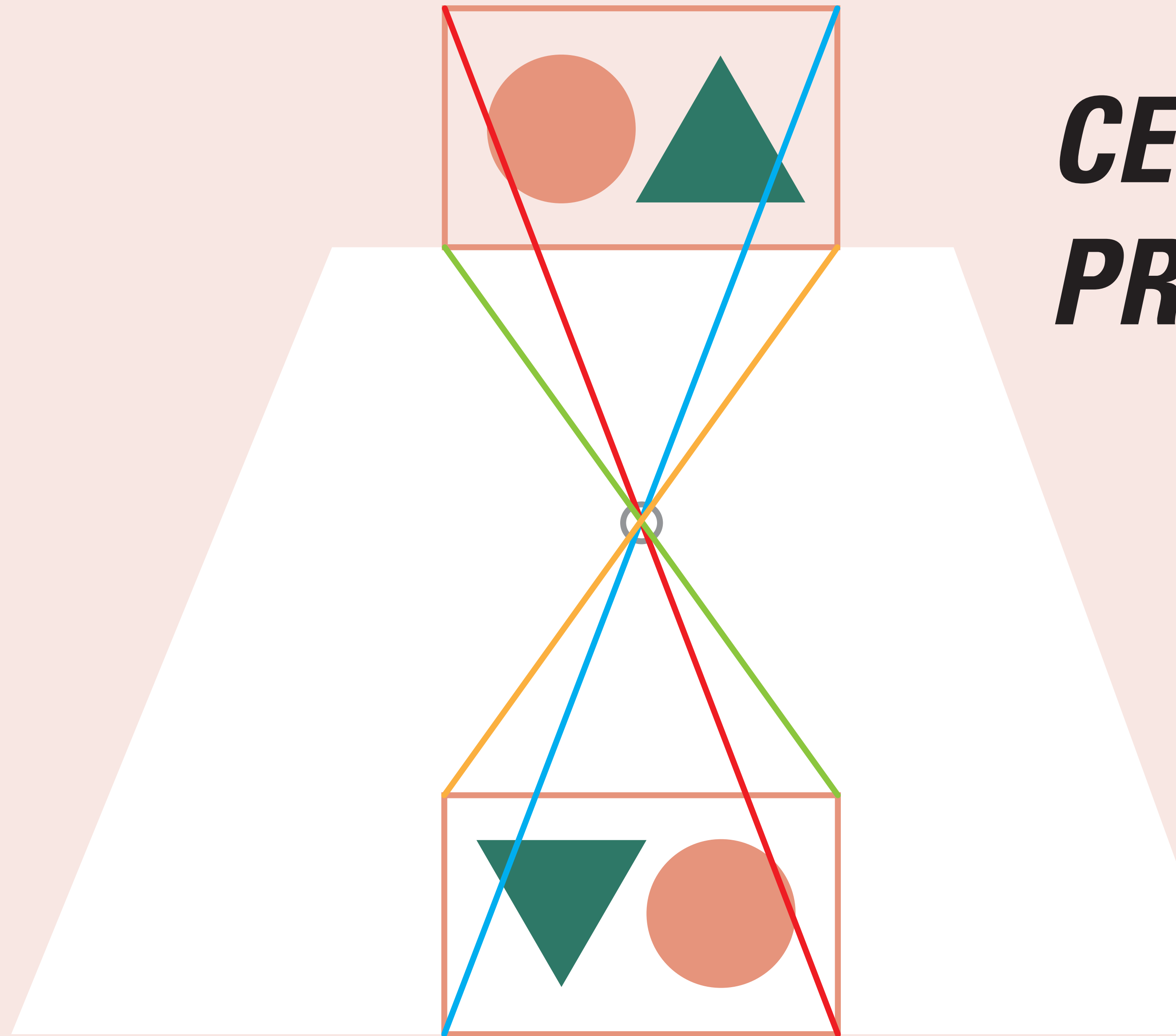

WEBCAM

BASES DA ÓTICA

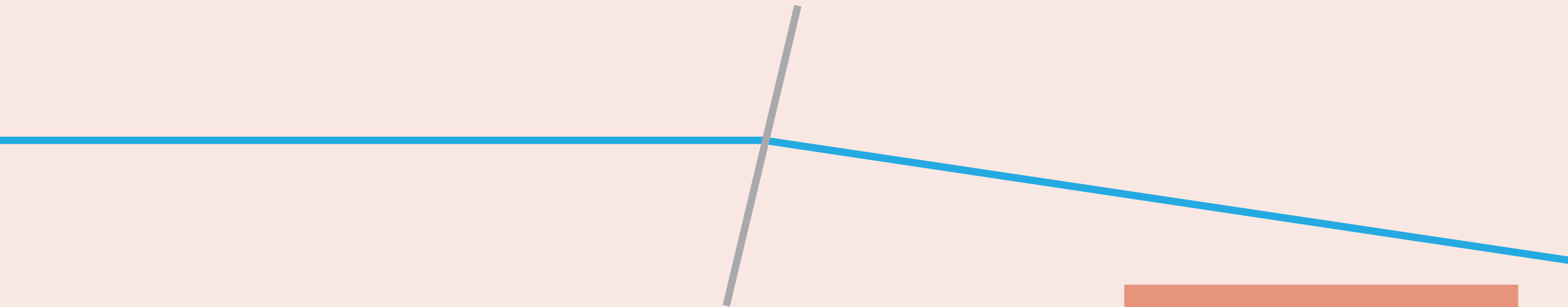

WEBCAM



BASES DA ÓTICA

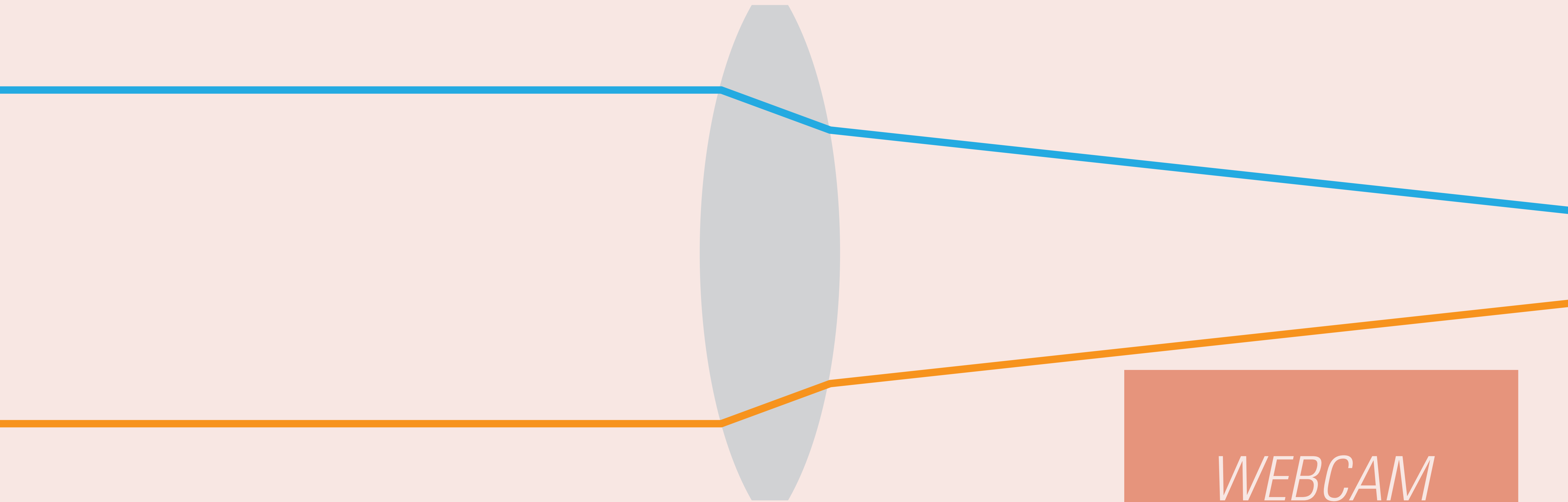

WEBCAM

BASES DA ÓTICA

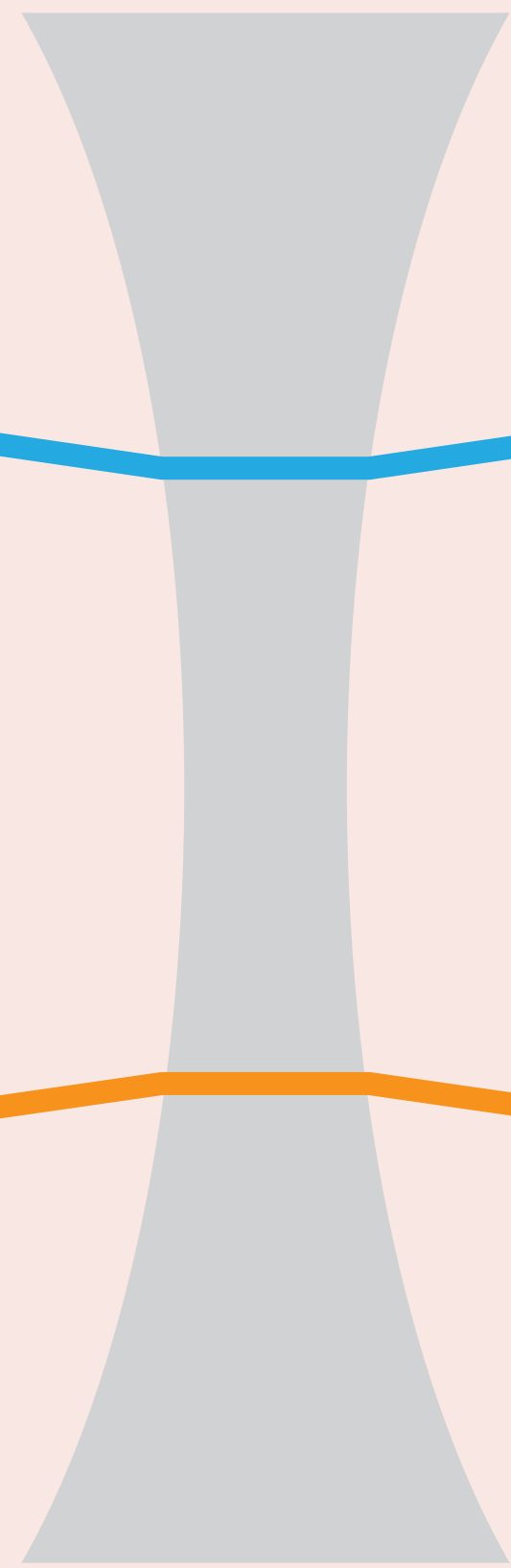

WEBCAM

BASES DA ÓTICA

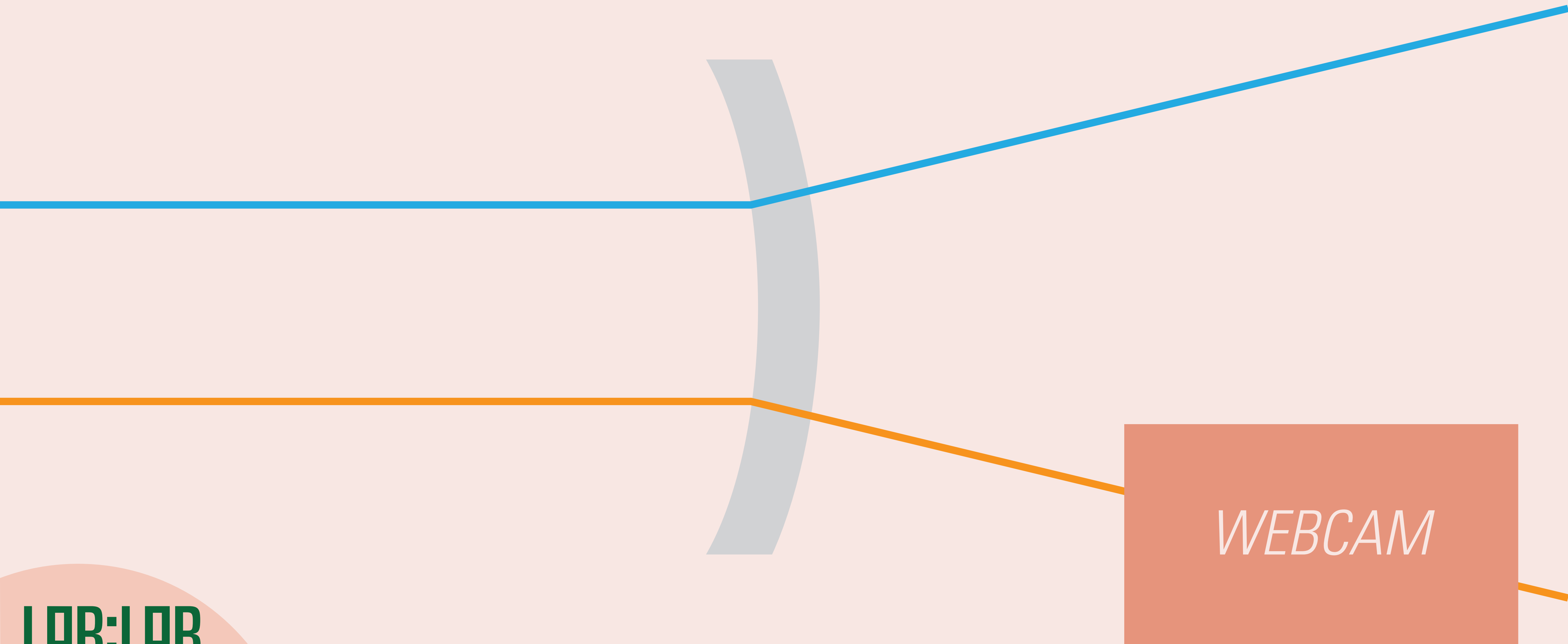

WEBCAM

BASES DA ÓTICA

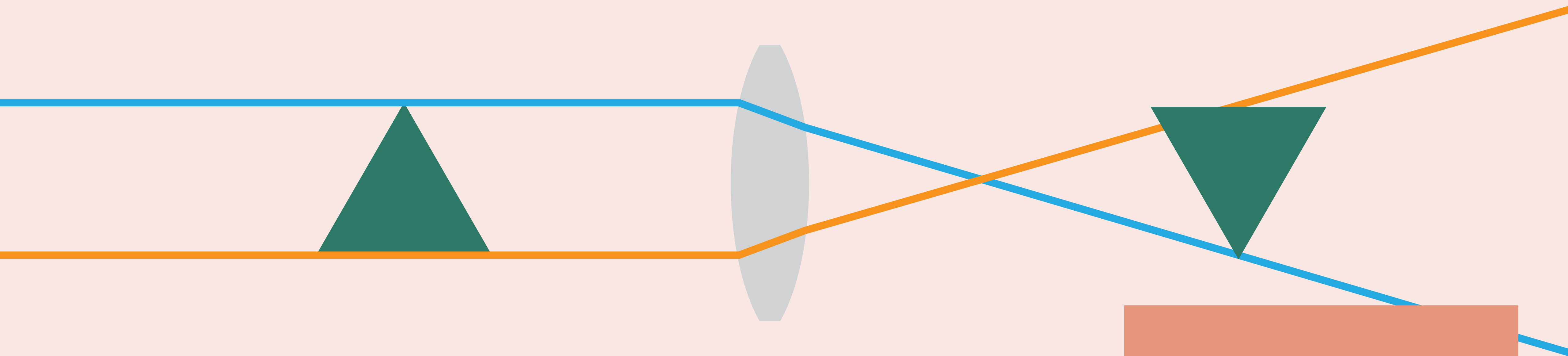

WEBCAM

DISTÂNCIA FOCAL

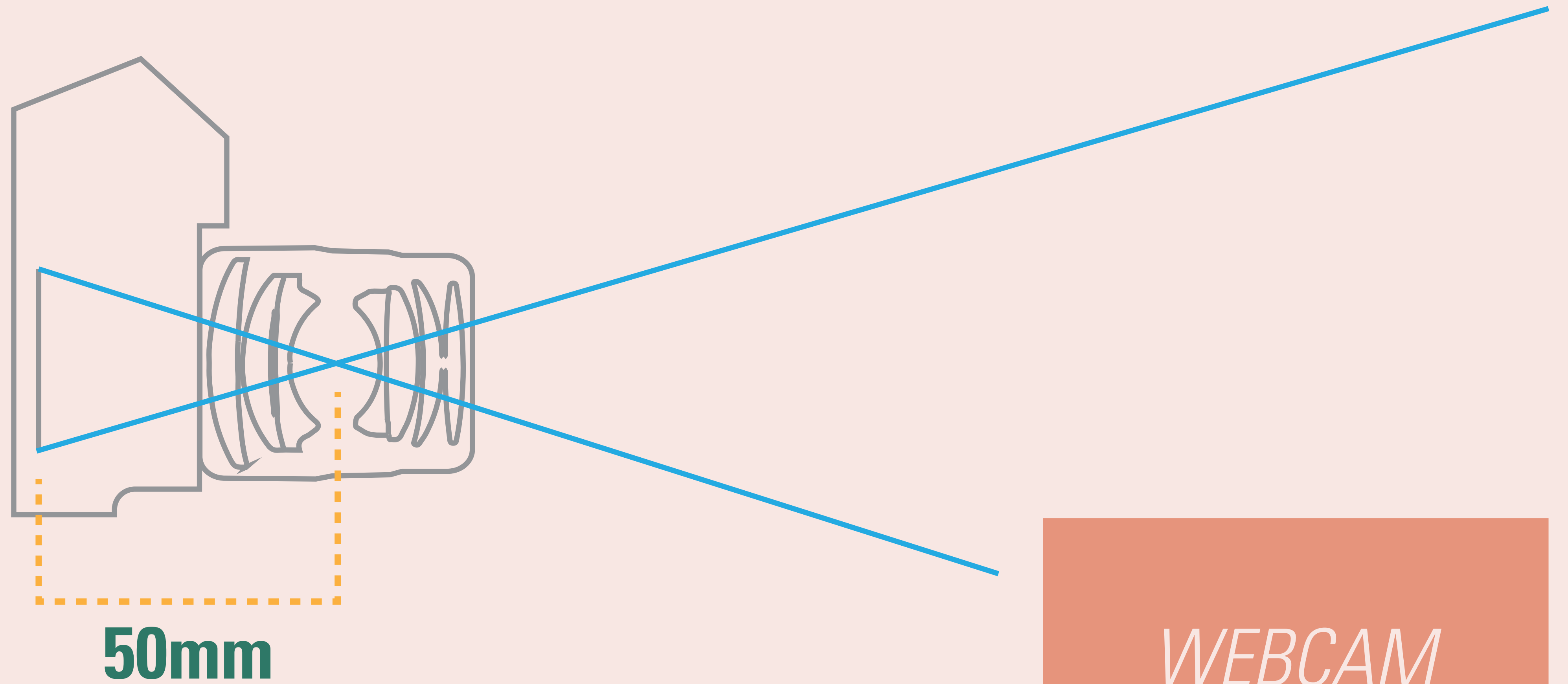

DISTÂNCIA FOCAL

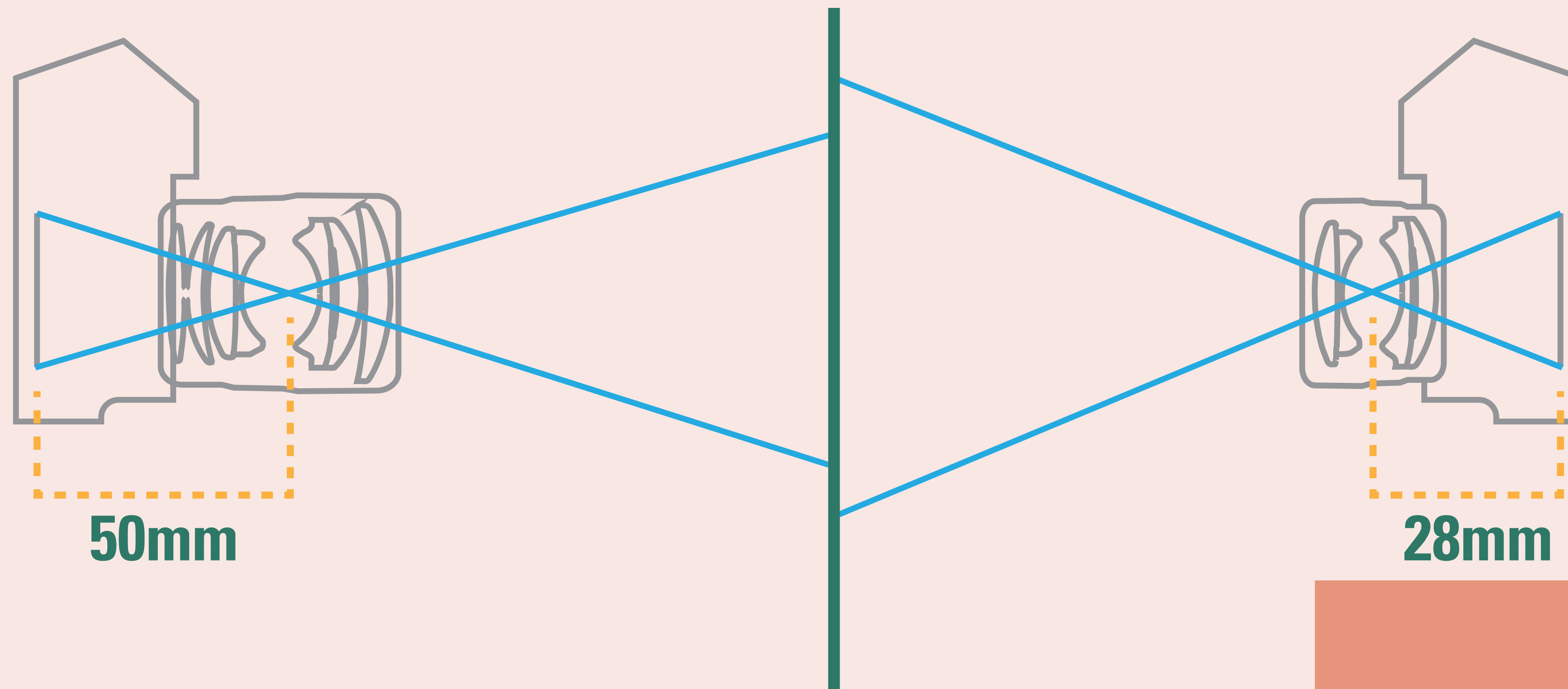

WEBCAM

DISTÂNCIA FOCAL

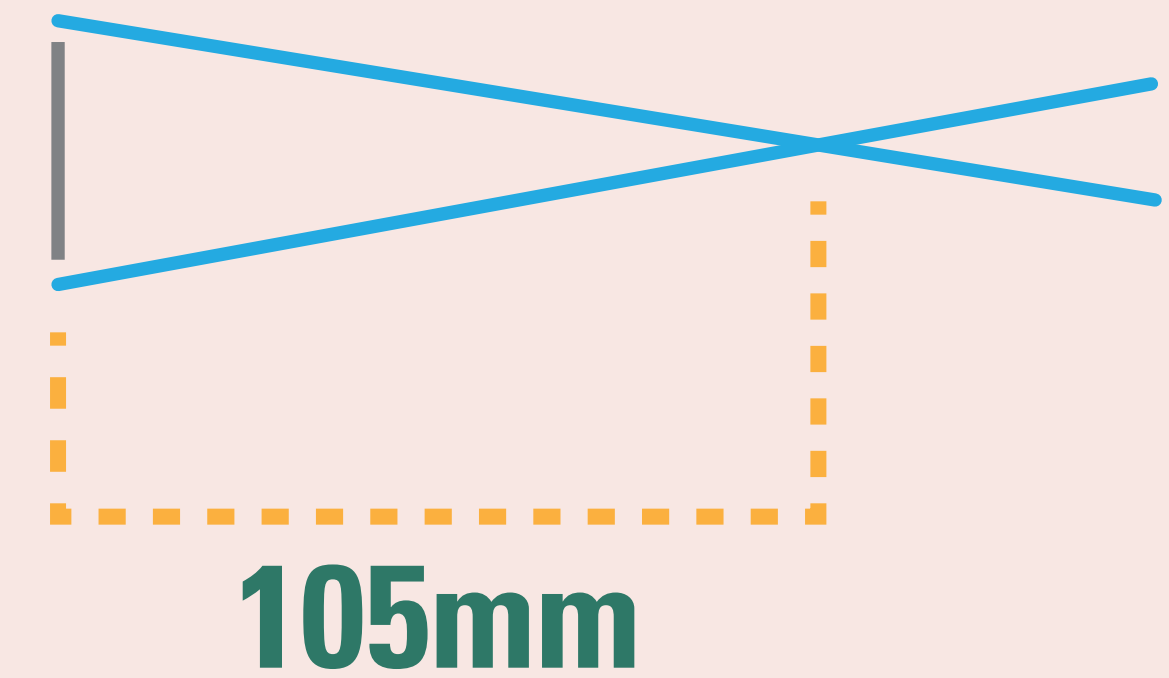
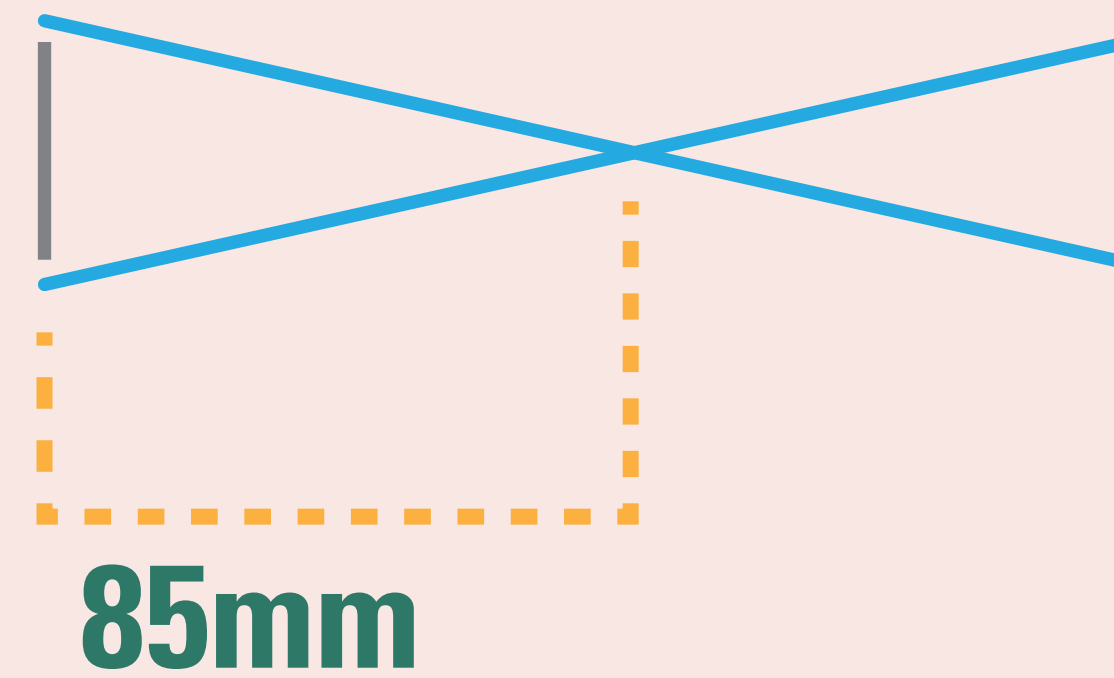
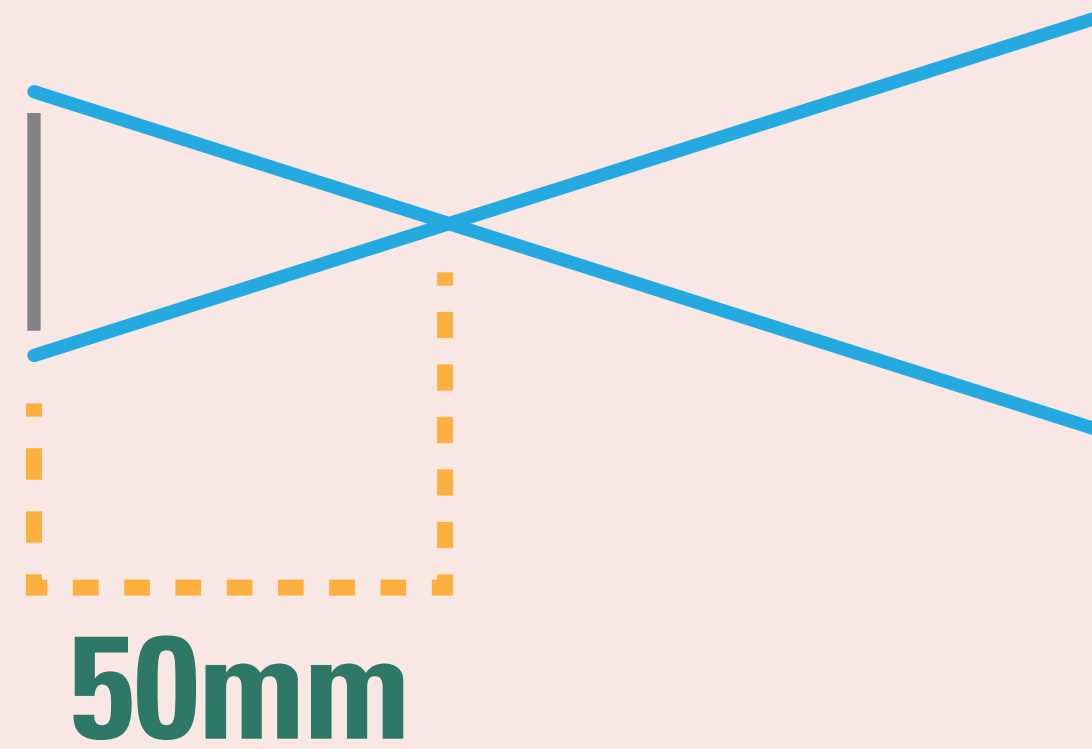
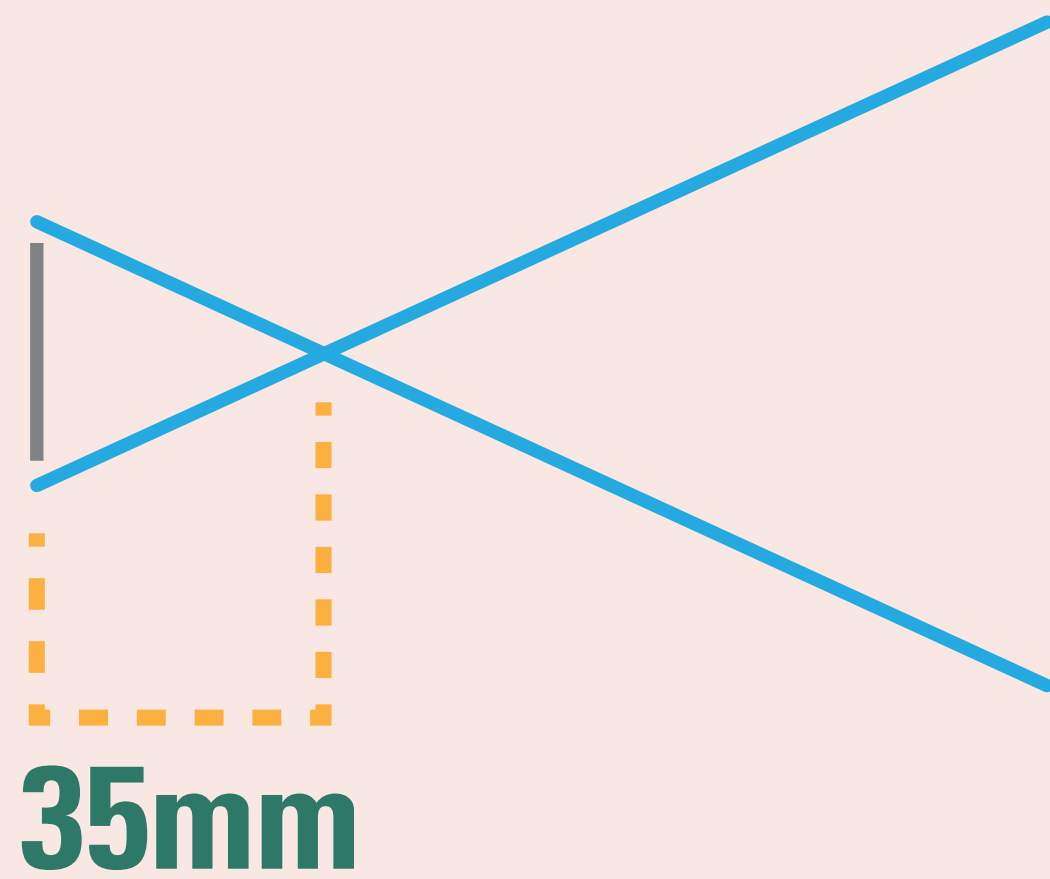

WEBCAM

DISTÂNCIA FOCAL E ÂNGULO DE VISÃO

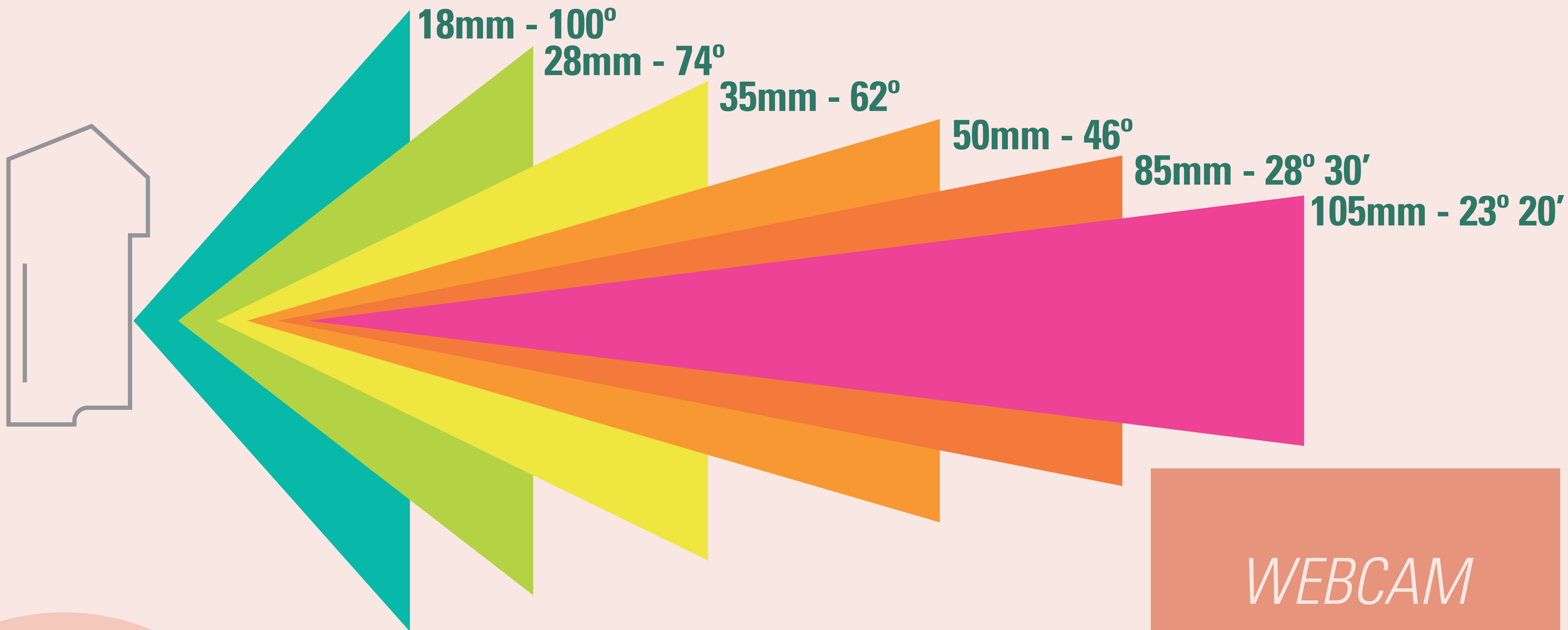

WEBCAM

DISTÂNCIAS FOCAIS NA MESMA CENA

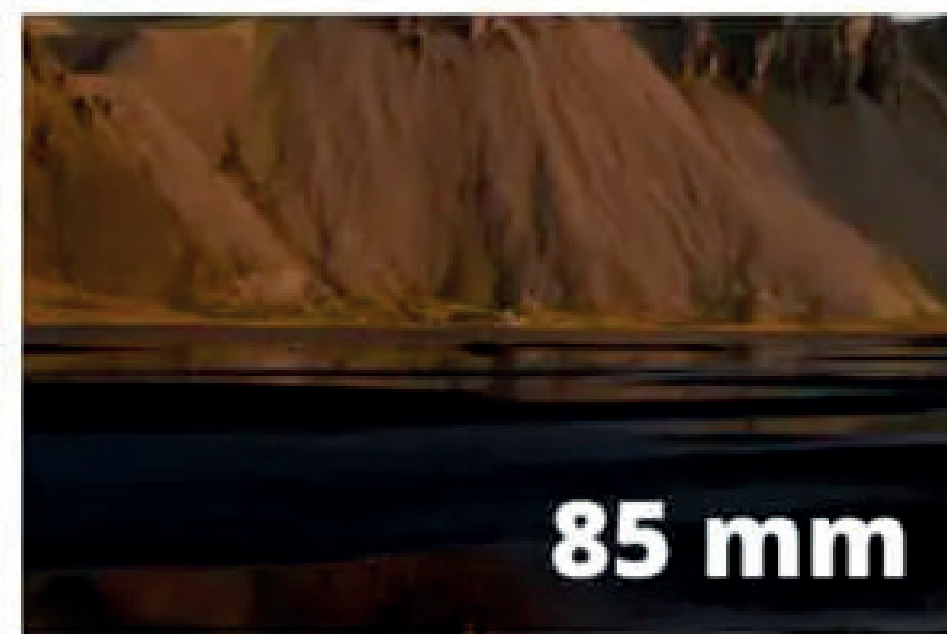

Fonte: Dan Zafra

WEBCAM

DIAFRAGMA

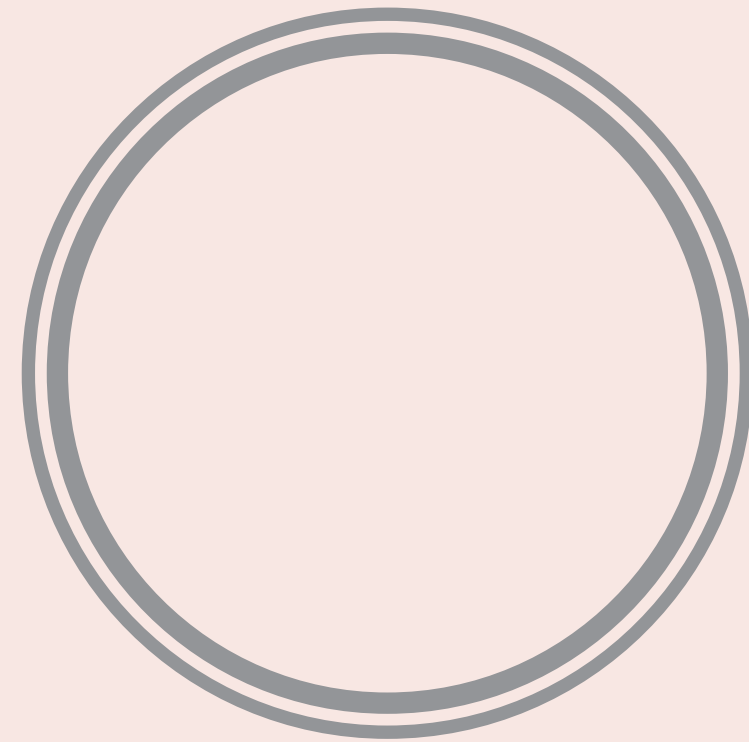

f2

"100%"

1

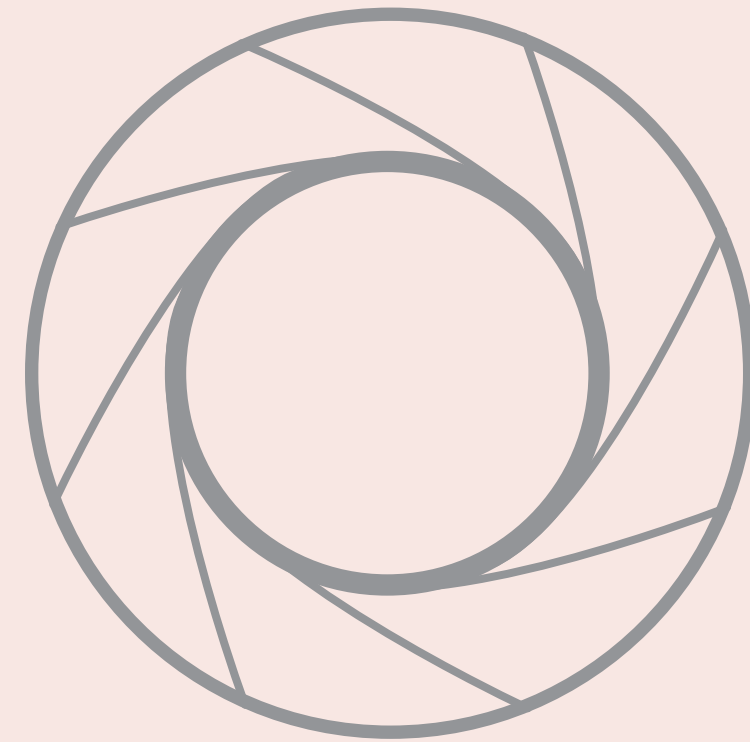

f2.8

"50%"

1/2

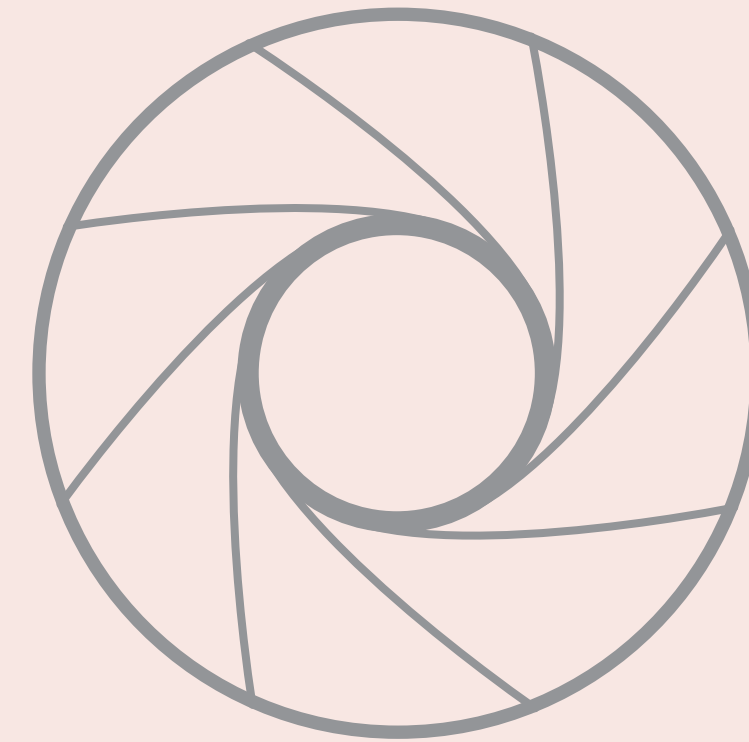

f4

"25%"

1/4

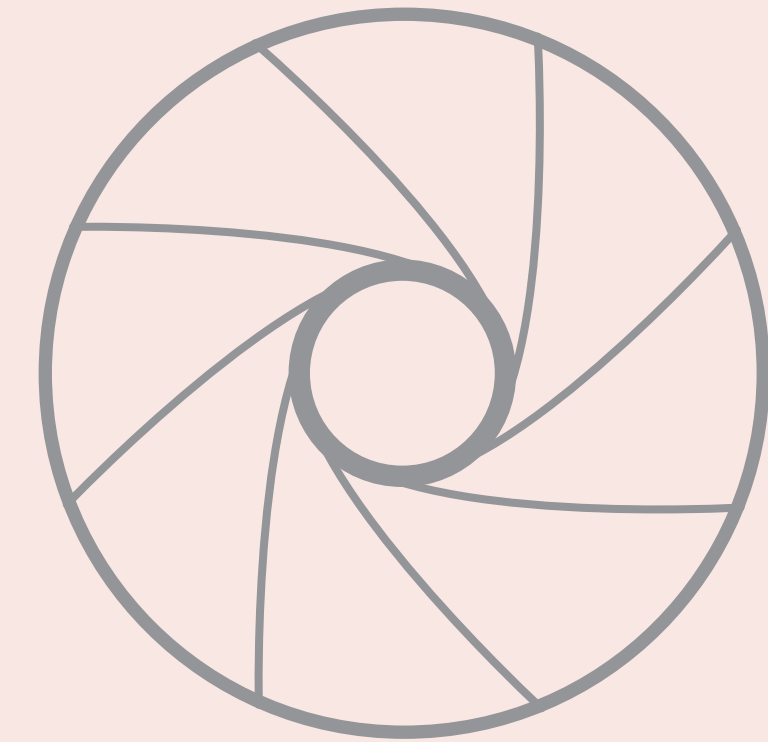

f5.6

"12,5%"

1/8

RELAÇÃO DE PROPORÇÃO DE LUZ

WEBCAM

ANALOGIA DA QUANTIDADE DE LUZ

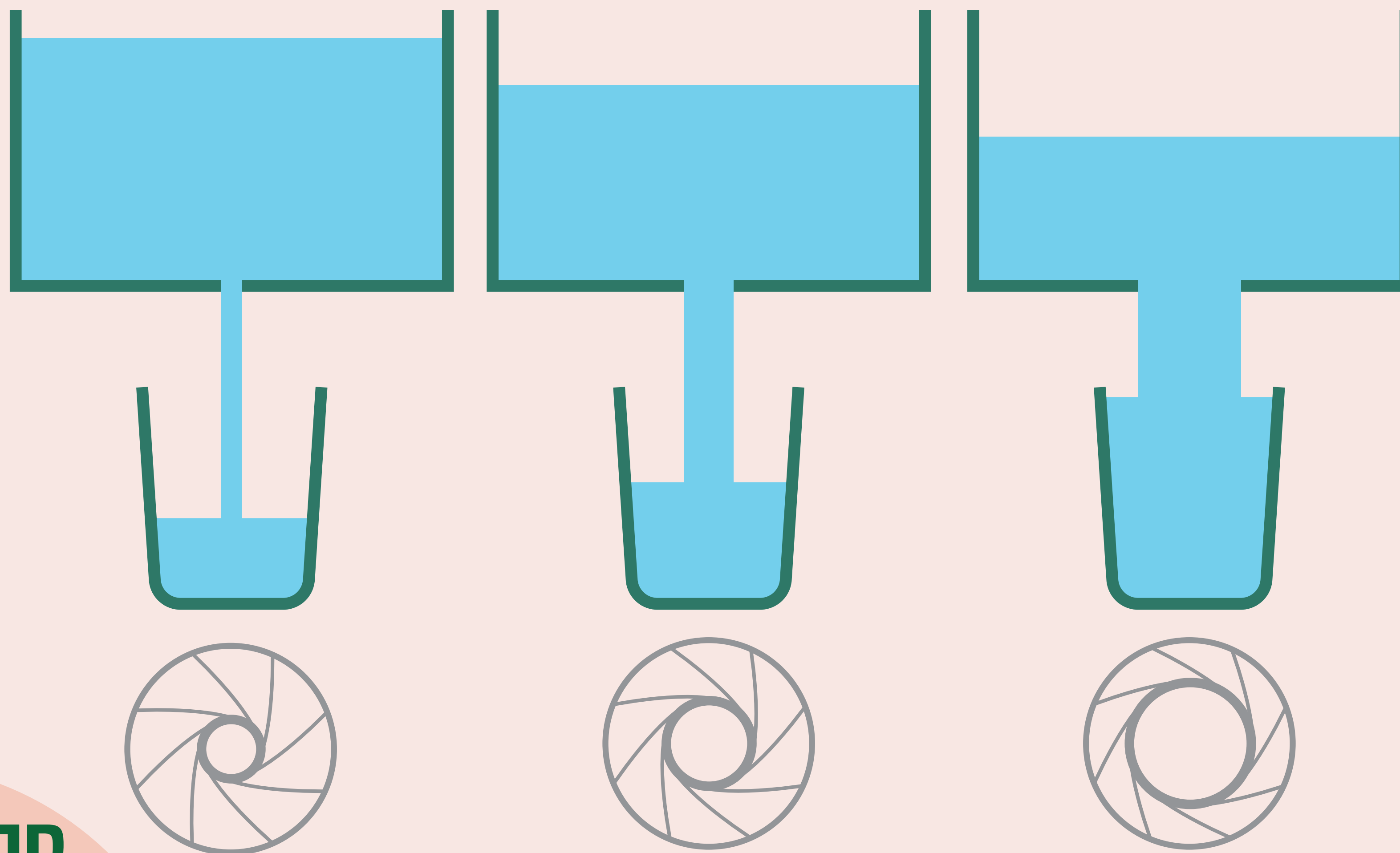

MESMA
TEMPO,
ABERTURAS
DIFERENTES

WEBCAM

ACHATAMENTO DE PLANOS



Fonte: Luca Eandi para Keh Camera

WEBCAM



16mm



105mm

ACHATAMENTO DE PLANOS

WEBCAM

ACHATAMENTO DE PLANOS

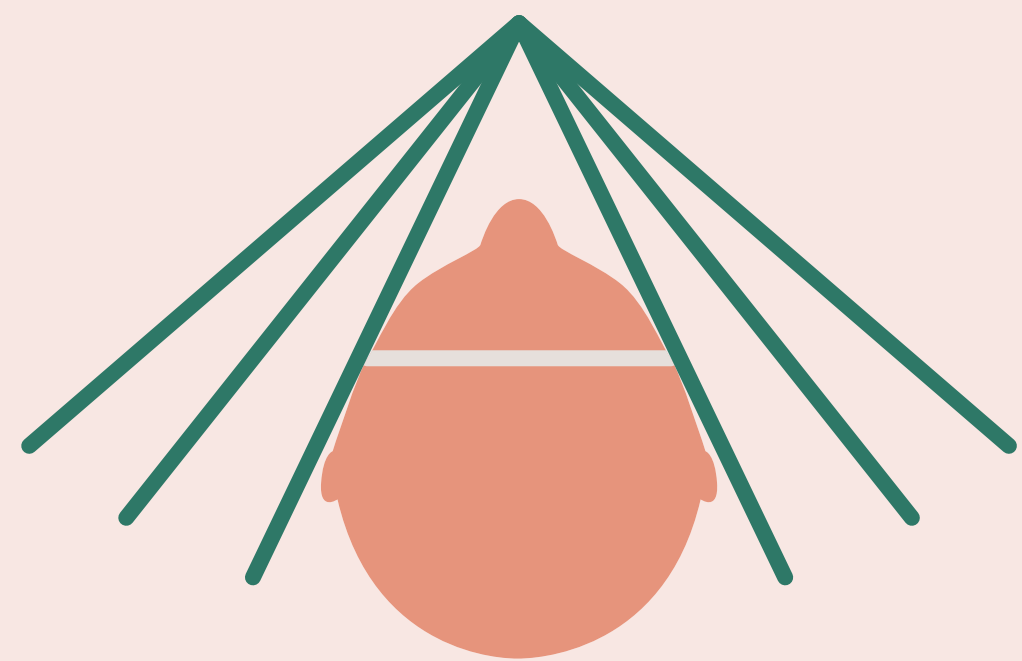

18mm

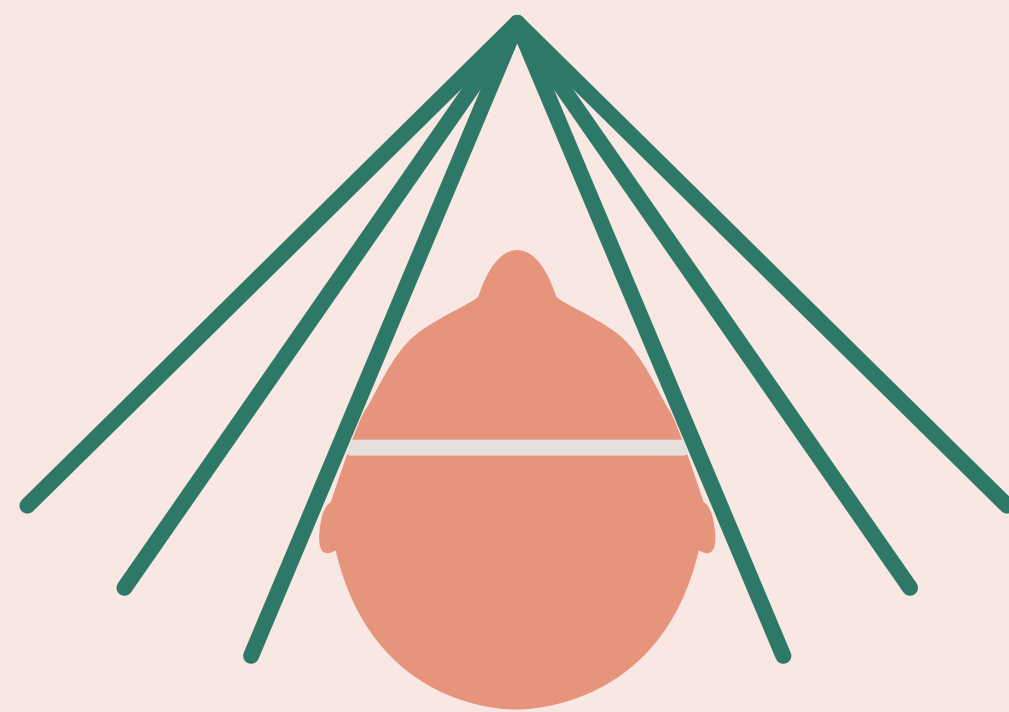

50mm

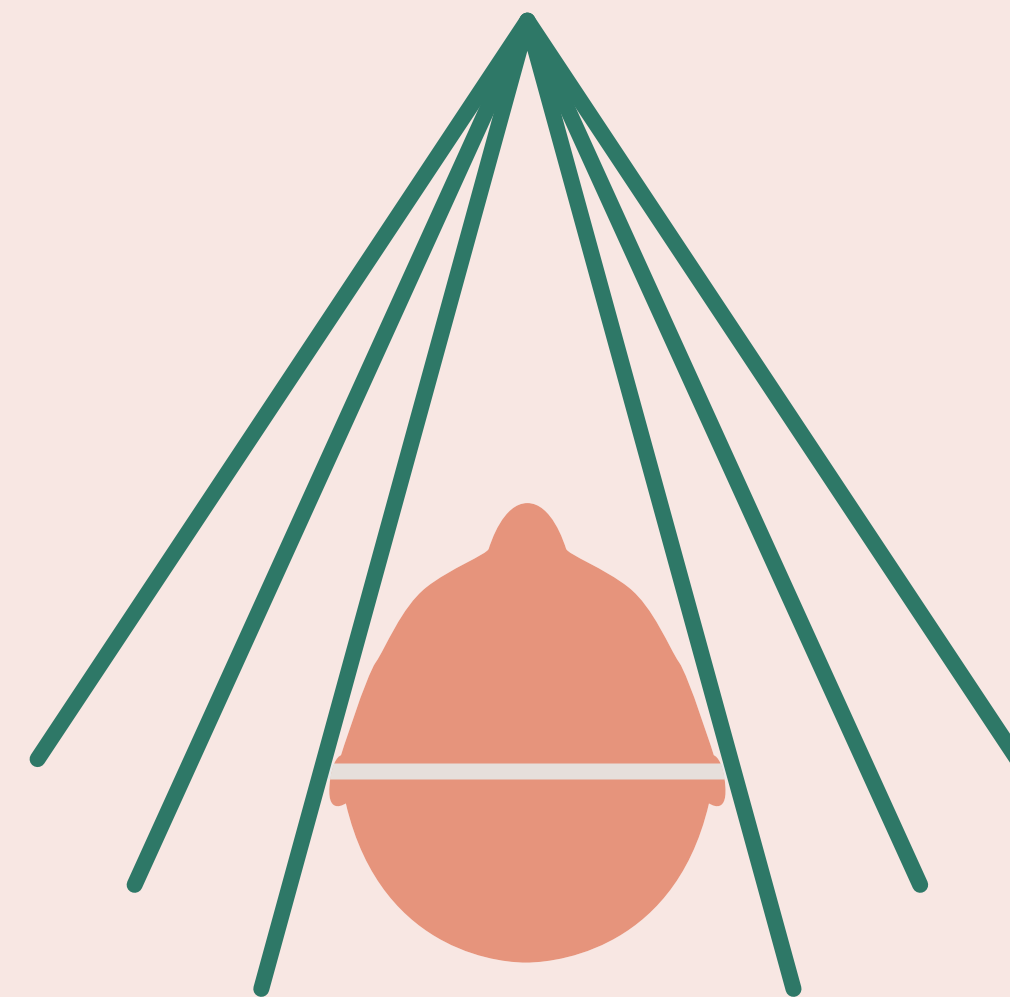

85mm

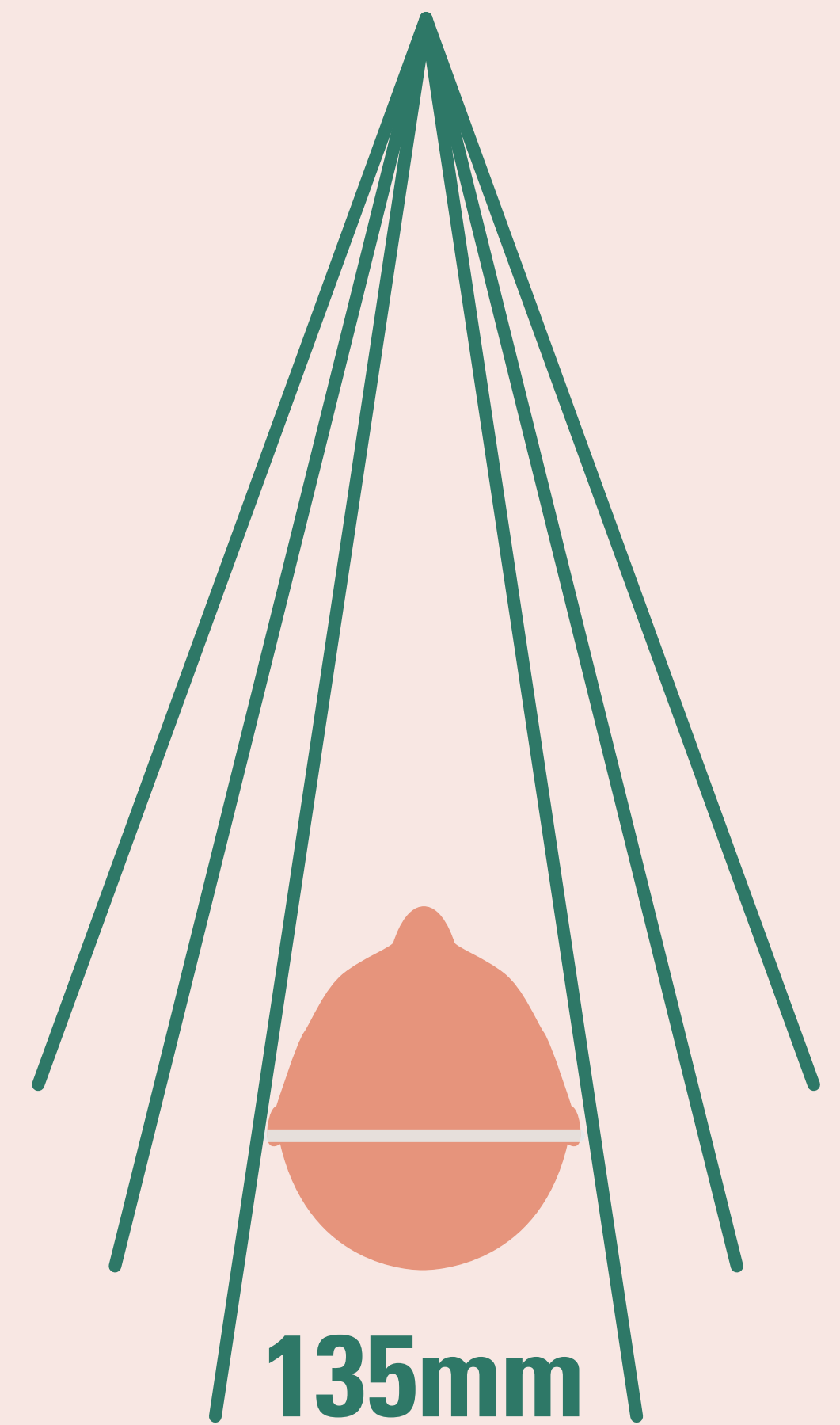

135mm

WEBCAM

ACHATAMENTO DE PLANOS

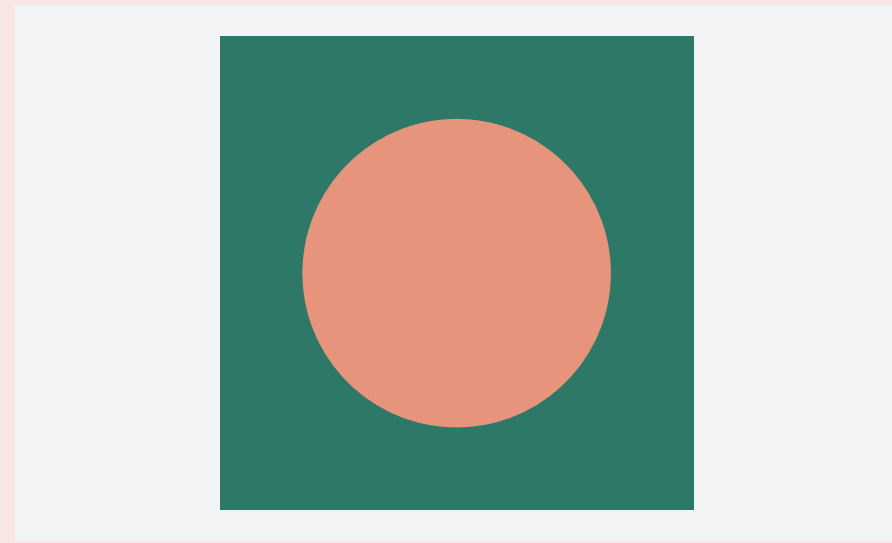

100mm

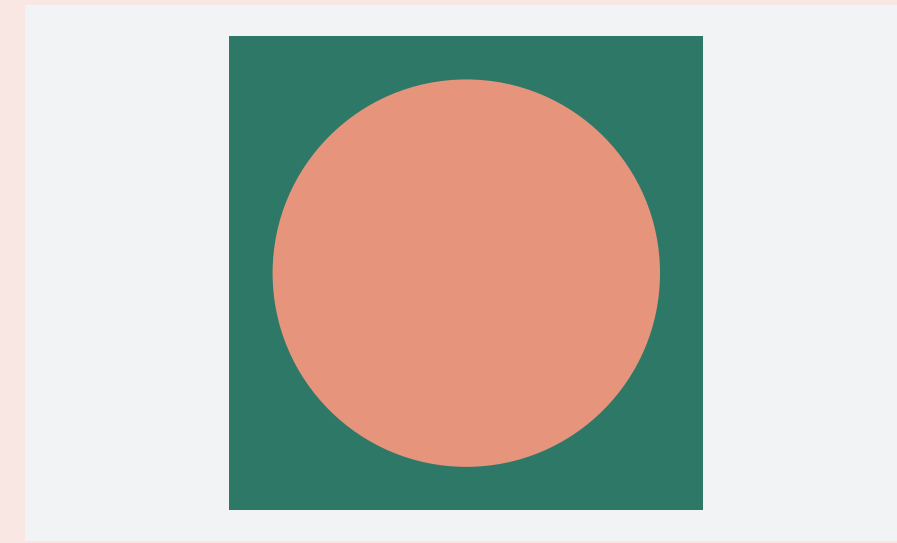
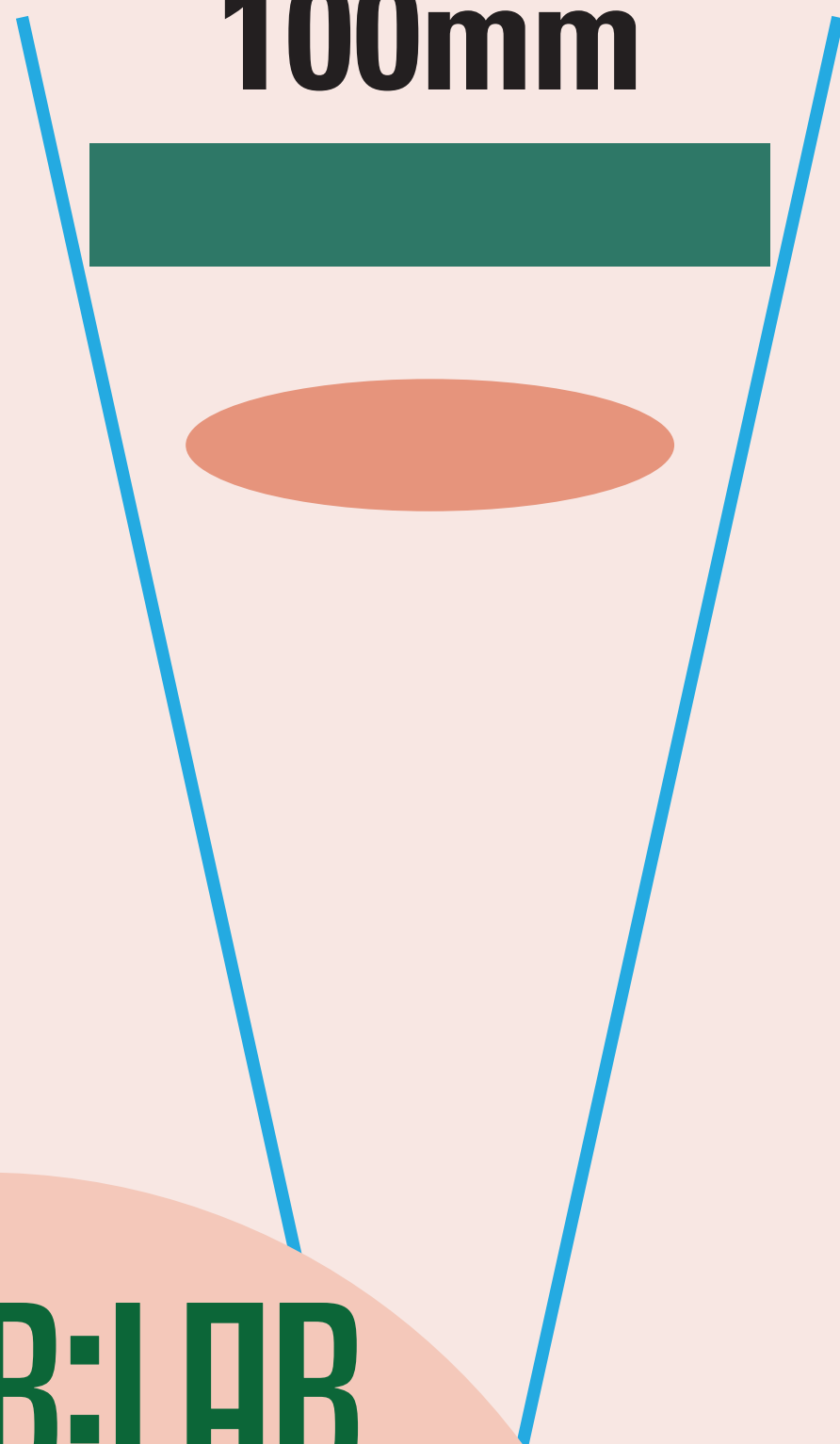

85mm

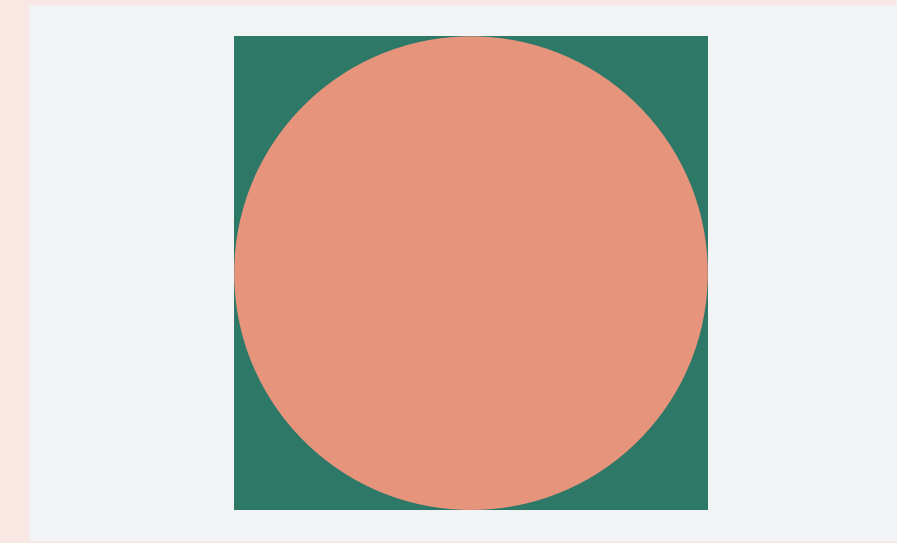
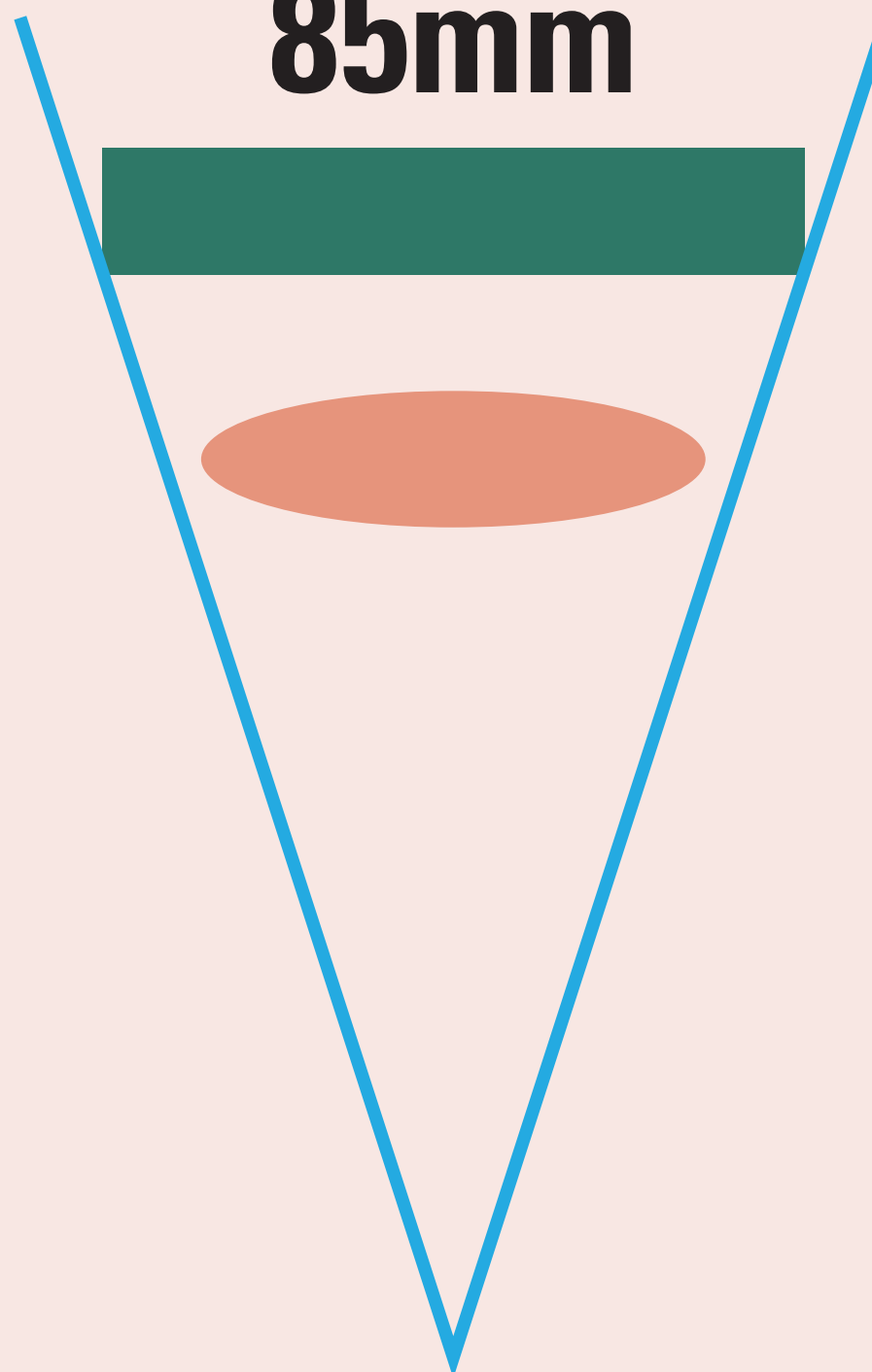

50mm

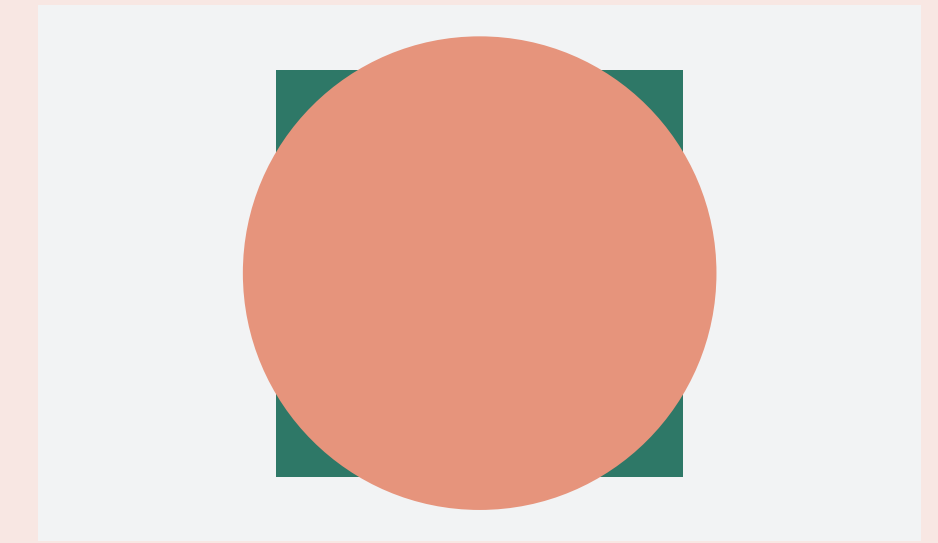
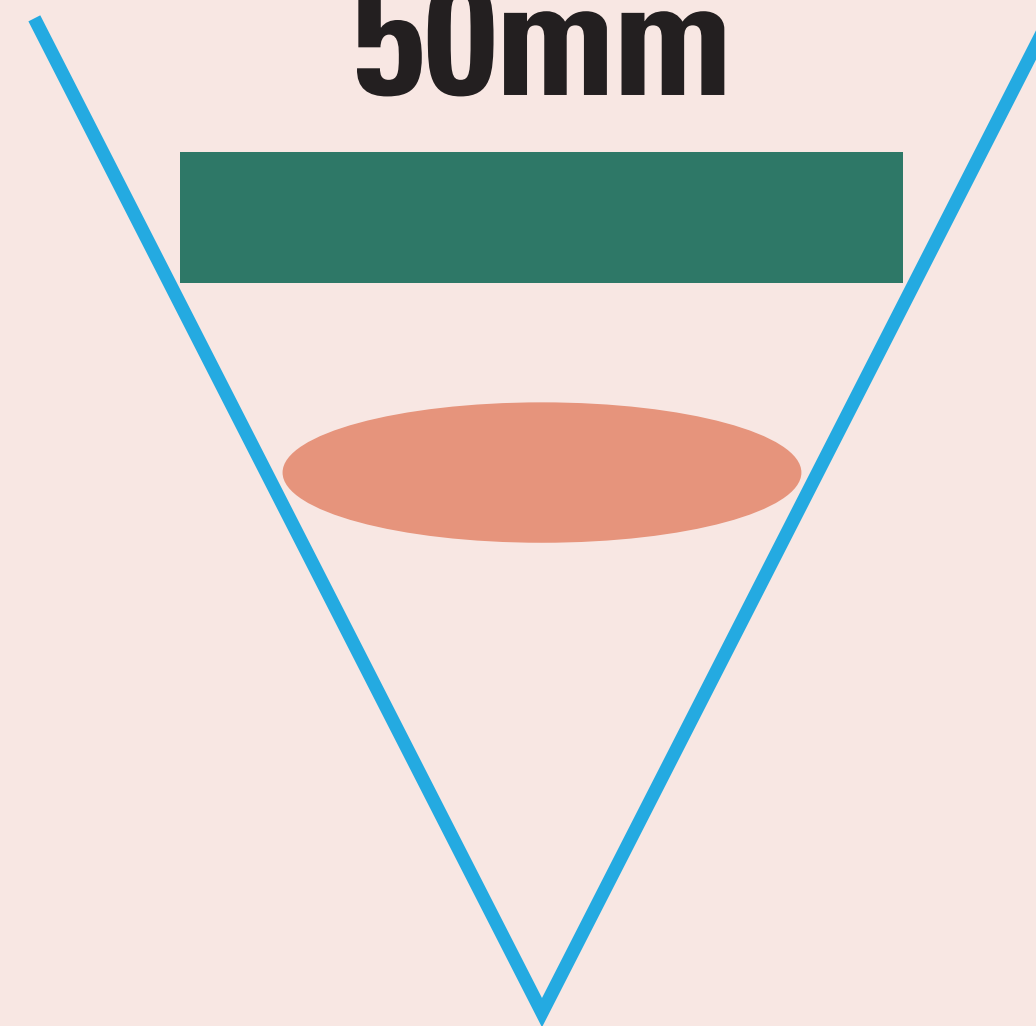

24mm

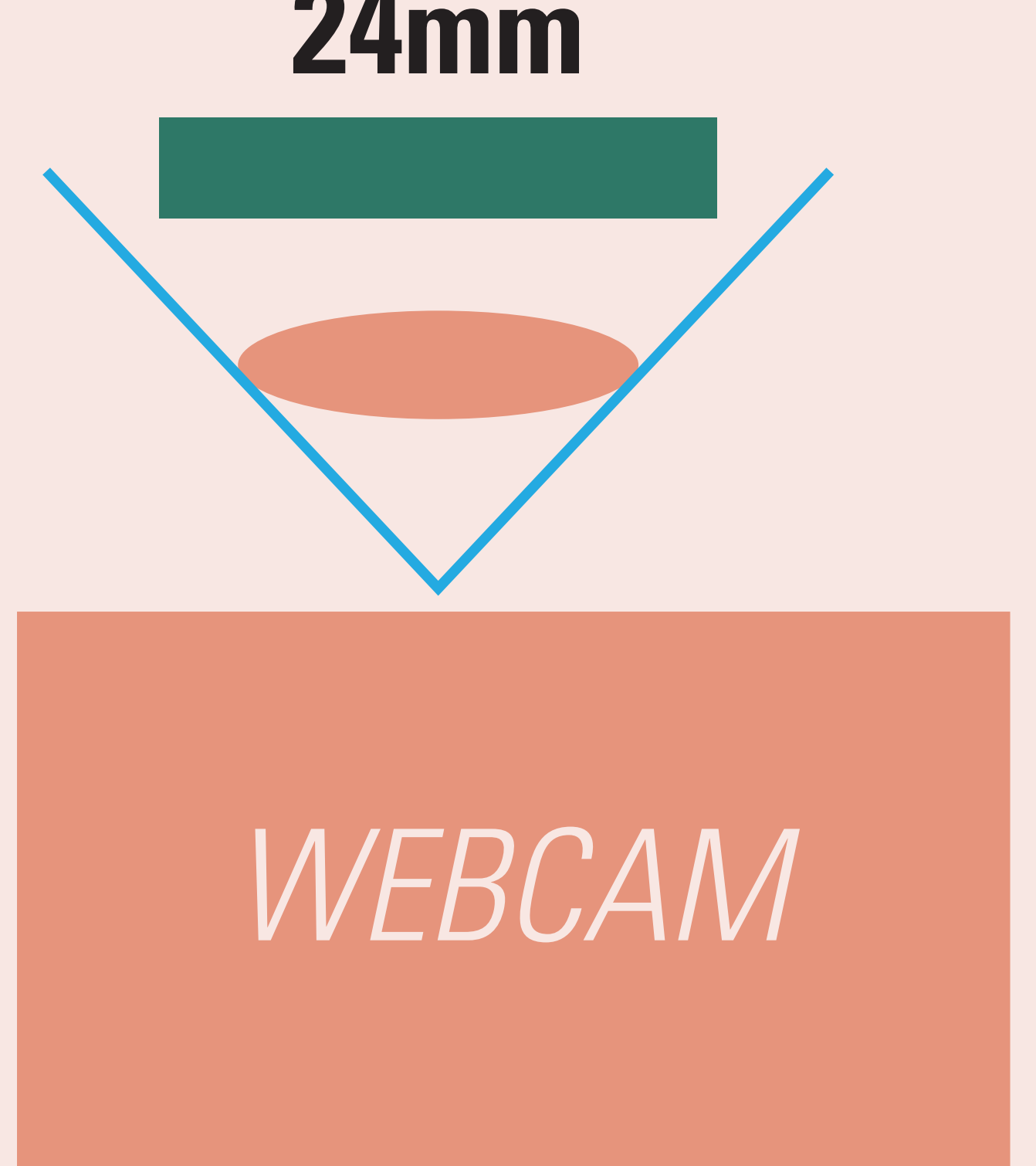

POR QUE NEM SEMPRE USAR **“50MM PARA RETRATOS”**

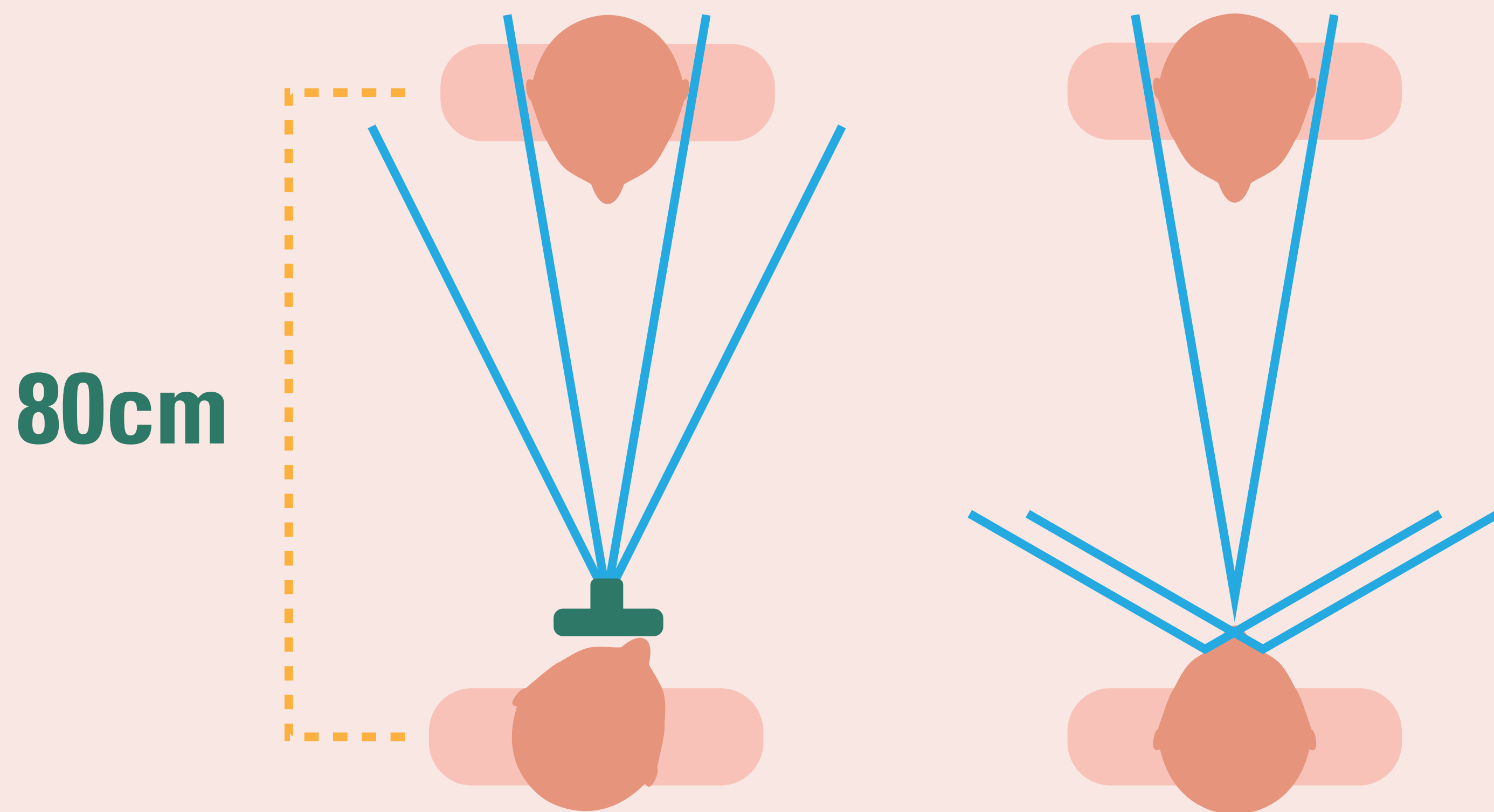

Em 45mm, a magnificação é próxima de 1:1 comparando um fotograma de filme 135 com a visão humana.

WEBCAM

PLANO MÉDIO CURTO

CÁLCULO DO DIAFRAGMA

DISTÂNCIA
FOCAL



ABERTURA
DO
DIAFRAGMA

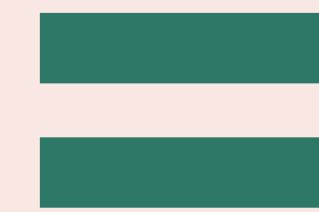

TAMANHO
FÍSICO DA
ABERTURA

WEBCAM

CÁLCULO DO DIAFRAGMA

DISTÂNCIA
FOCAL

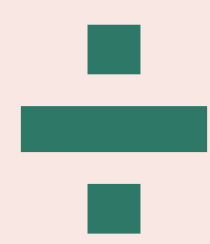

ABERTURA
DO
DIAFRAGMA



TAMANHO
FÍSICO DA
ABERTURA

110



2.8



39

abertura
selecionada
na lente

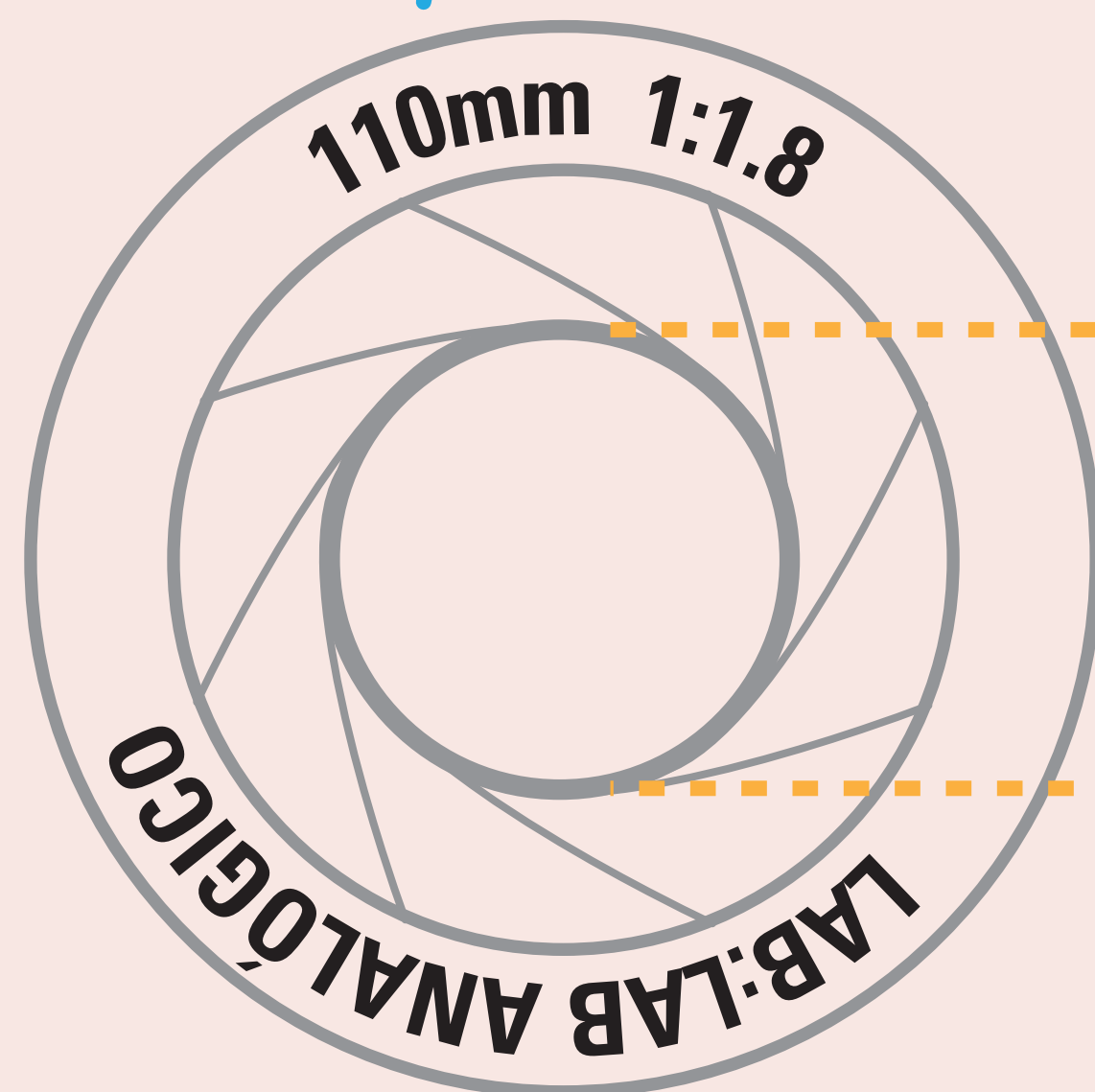

39mm

WEBCAM

PROFUNDIDADE DE FOCO E DIAFRAGMA

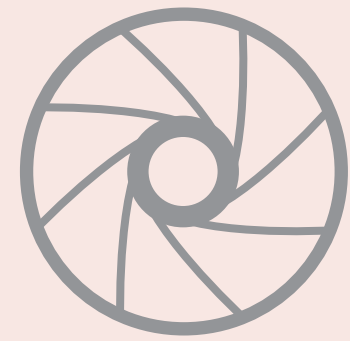

f5.6

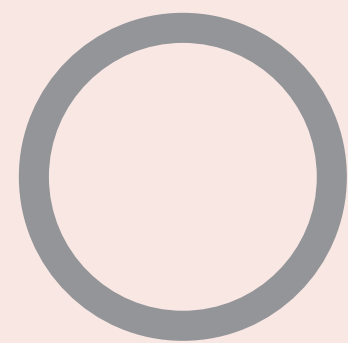

f2

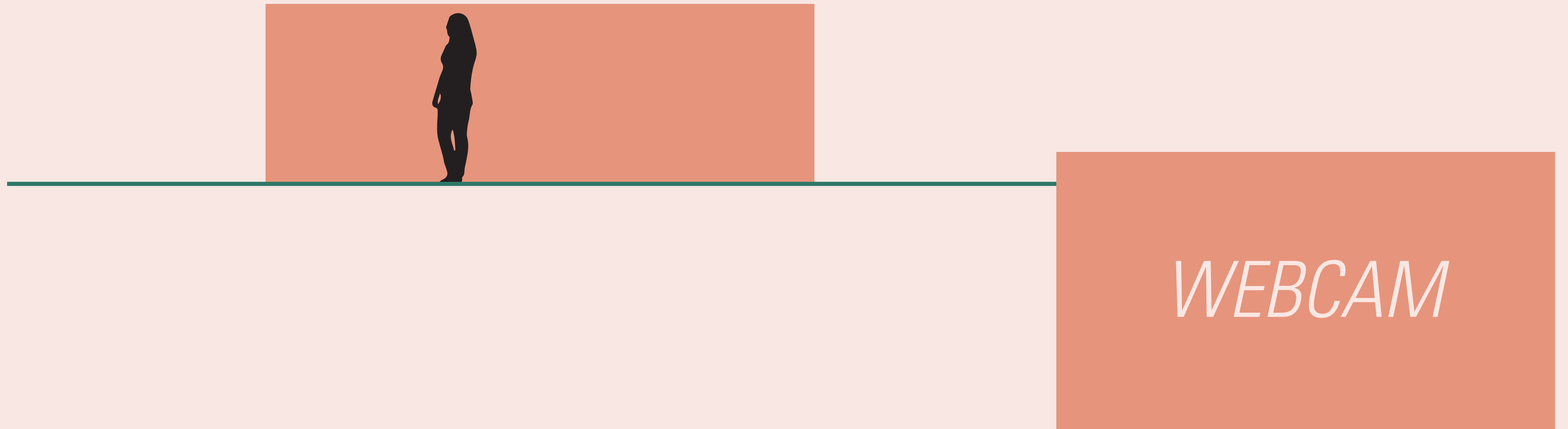

WEBCAM

ABERTURA E PROFUNDIDADE DE CAMPO

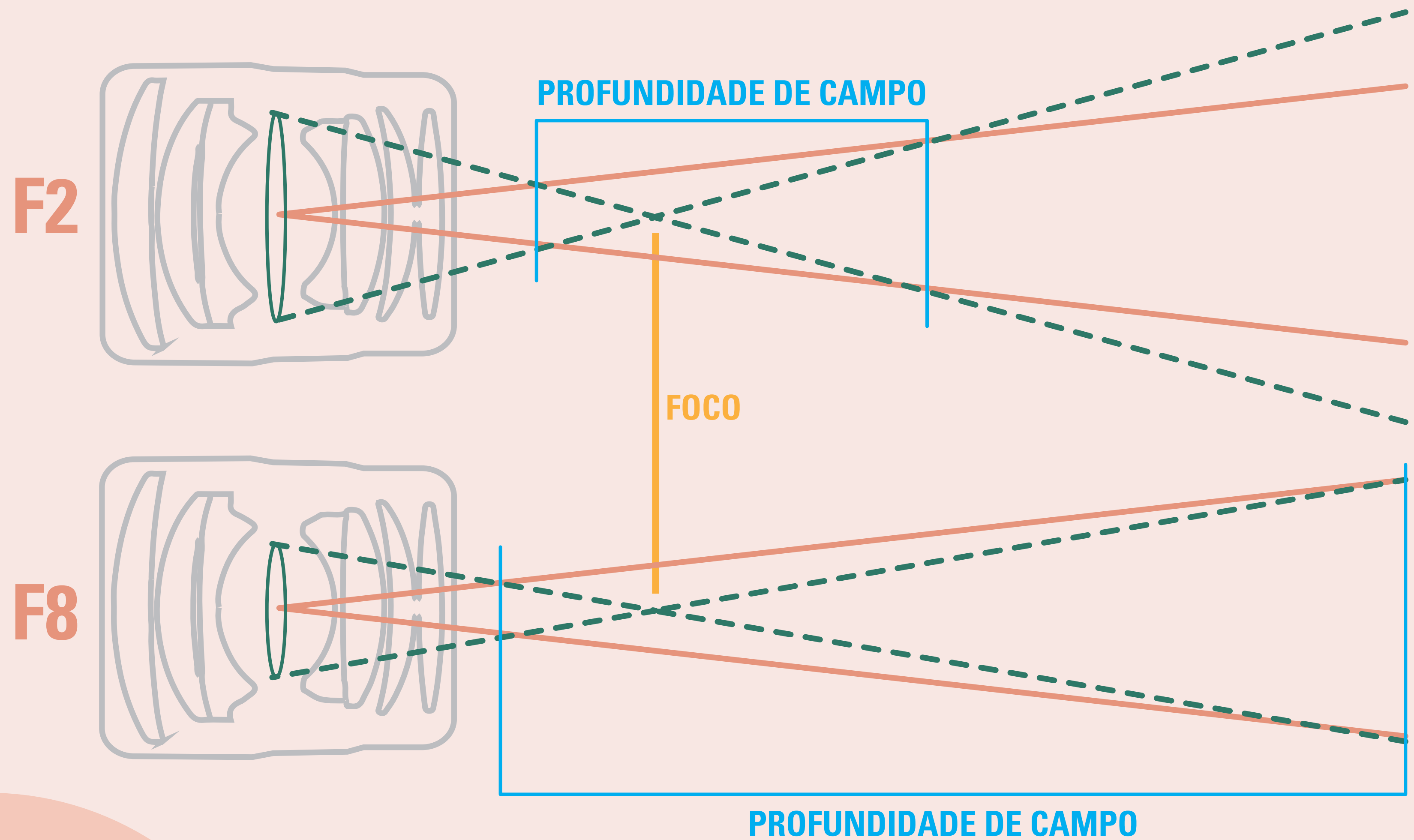

WEBCAM

PROFUNDIDADE DE CAMPO E DIAFRAGMA



Fonte: Pallibi Photo

WEBCAM

COMPARATIVO DE FORMATOS EM ESCALA

4x5"
124cm²

120
6x4,5
27cm²

120
6x6
36cm²

120
6x7
42cm²

135
8,6cm²

110
2,5cm²

WEBCAM

DIFERENÇAS DE ÂNGULO DE COBERTURA PEQUENO E MÉDIO FORMATO

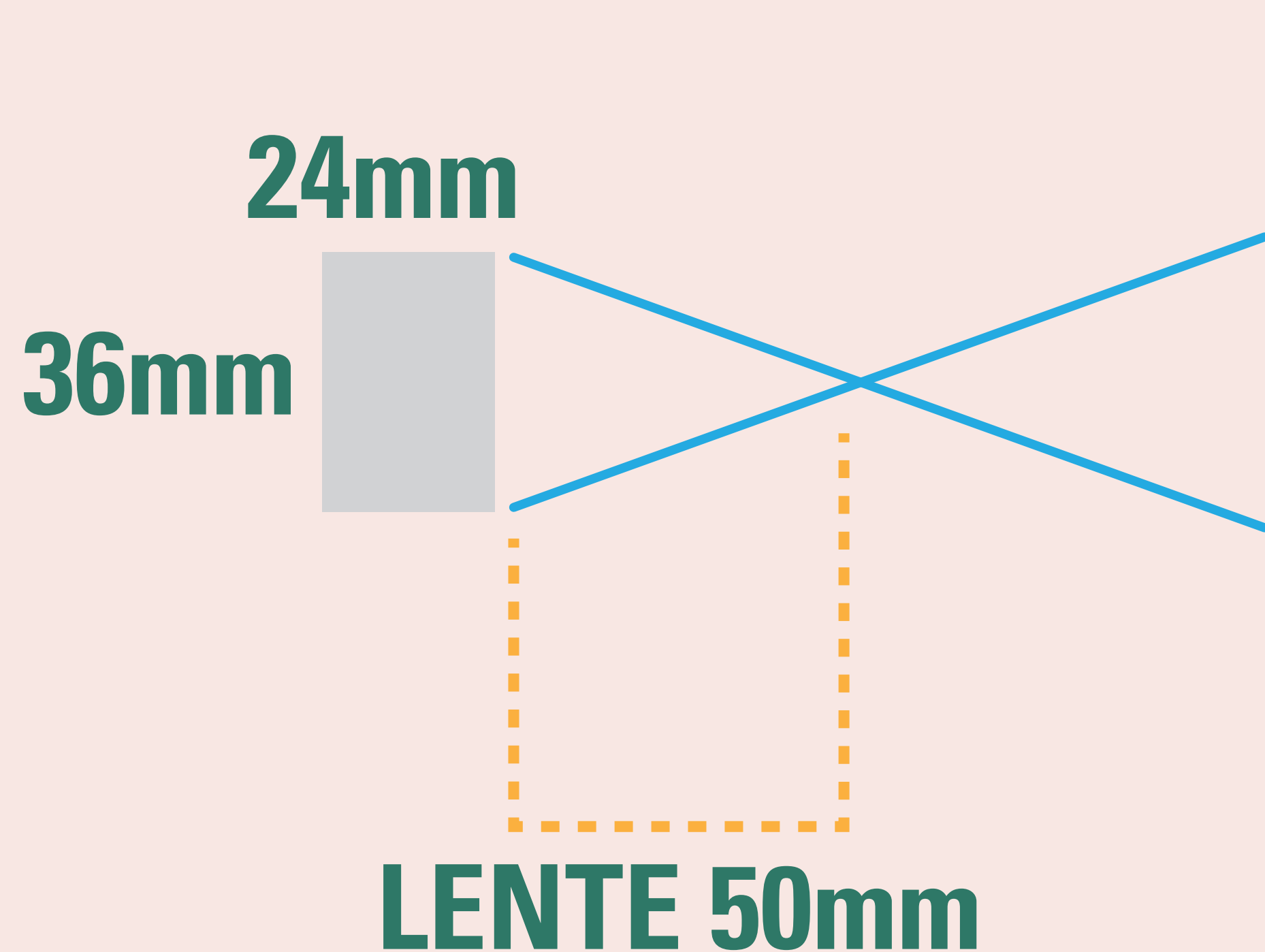

PEQUENO FORMATO
FILME 135

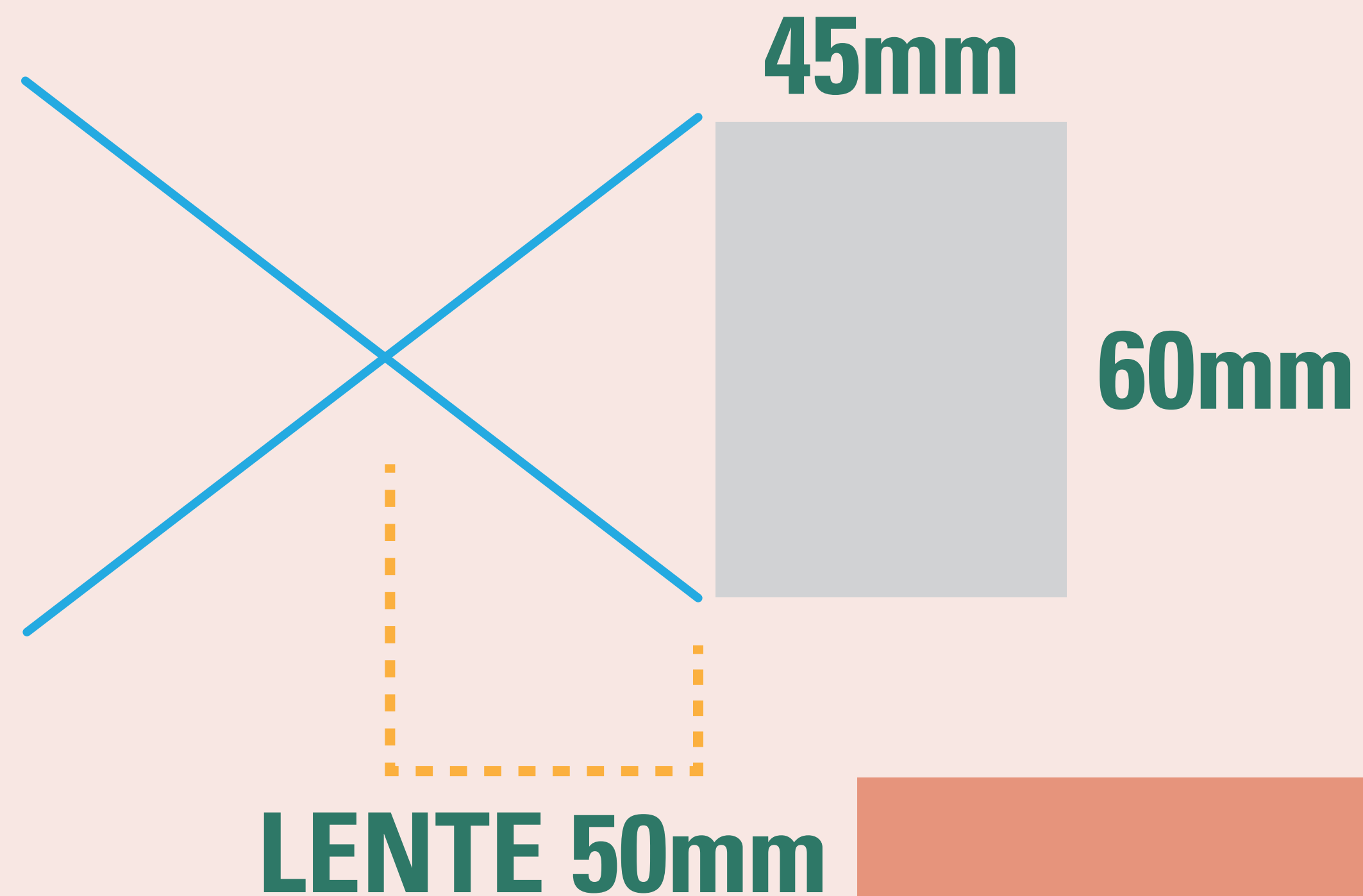

MÉDIO FORMATO
FILME 120 - 6x45

WEBCAM

RELAÇÃO ENTRE ÂNGULO DE VISÃO ENTRE PEQUENO E MÉDIO FORMATO

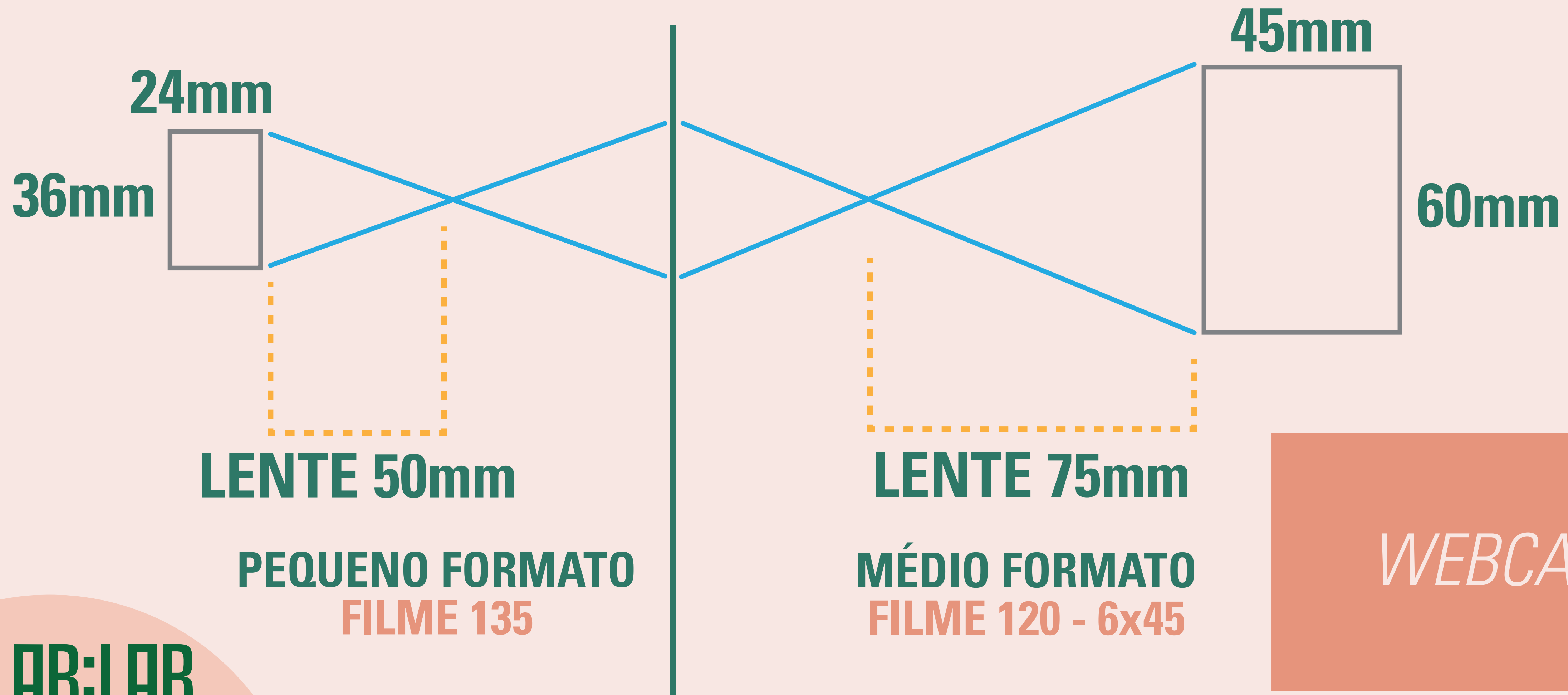

RELAÇÃO ENTRE ÂNGULO DE VISÃO ENTRE PEQUENO E MÉDIO FORMATO

PEQUENO FORMATO
FILME 135

24mm

35mm

50mm

85mm

100mm

MÉDIO FORMATO
FILME 120 - Câmera 6x45

35mm

50mm

75mm

100mm

150mm

FILME 120 - Câmera 6x6

40mm

60mm

80mm

120mm

160mm

FILME 120 - Câmera 6x7

50mm

75mm

100mm

150mm

200mm

WEBCAM

RELAÇÃO ENTRE ABERTURAS ENTRE **PEQUENO E MÉDIO FORMATO**

f2.8

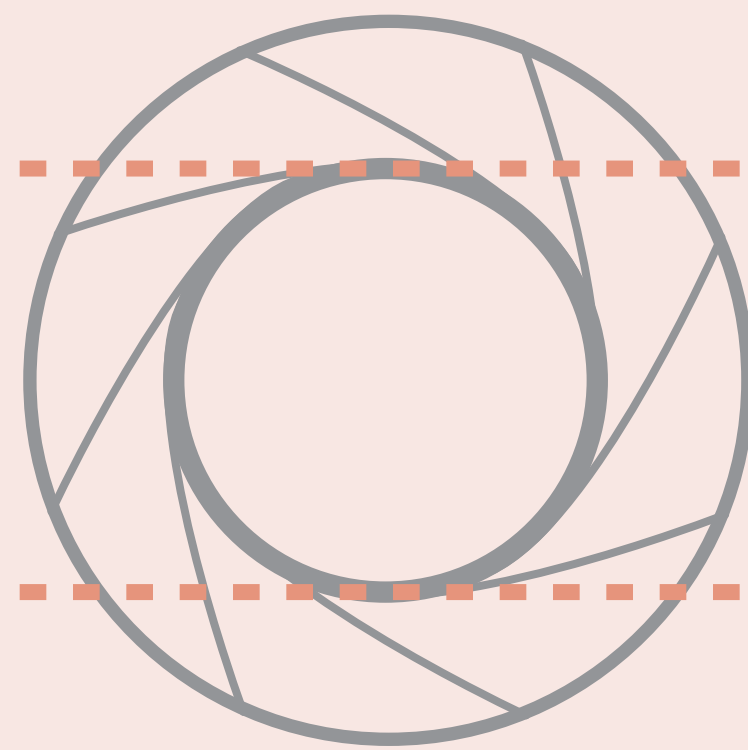

**LENTE
PEQUENO
FORMATO**

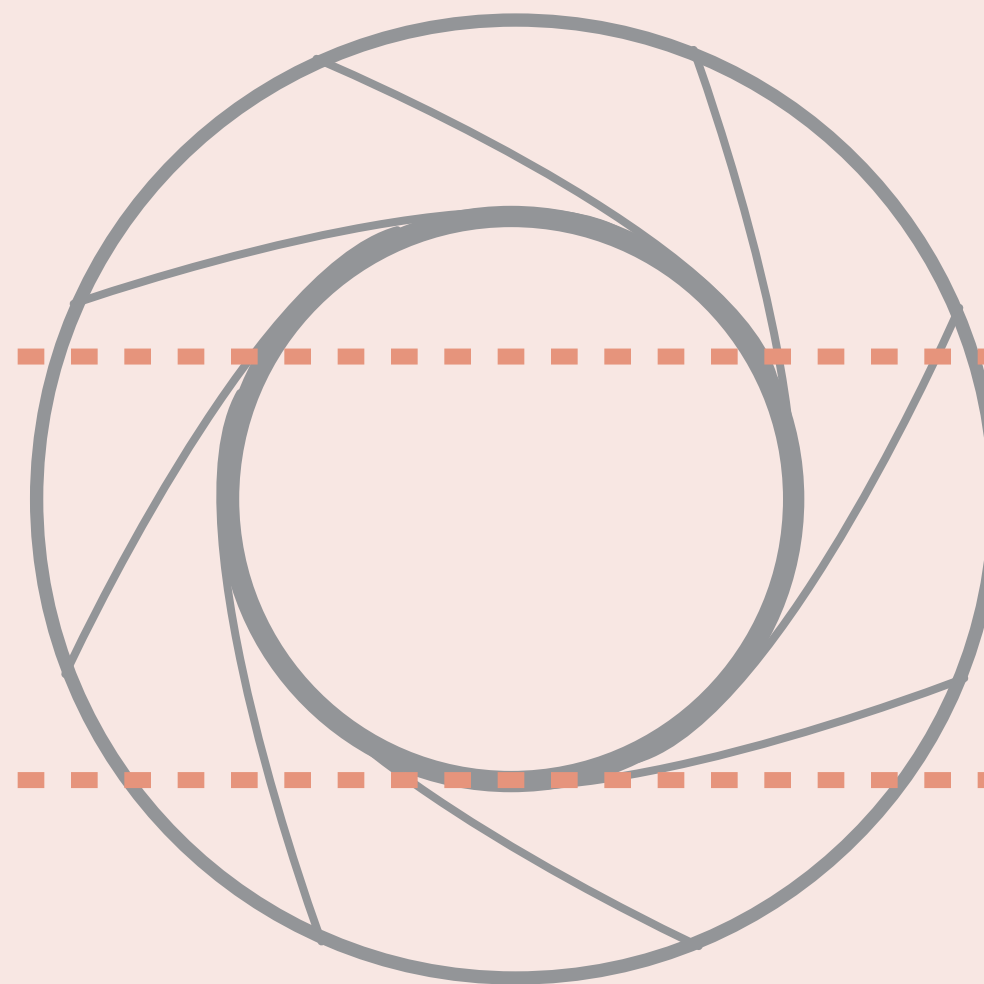

**LENTE
MÉDIO
FORMATO**

WEBCAM

COMPARATIVO DO BOKEH / PROFUNDIDADE DE CAMPO

PEQUENO, MÉDIO E GRANDE FORMATO



PEQUENO F.
50mm

MÉDIO F.
85mm

GRANDE F.
300mm

TODAS
f4.5

WEBCAM

Fonte: John Aldred

COMPARATIVO DO BOKEH / PROFUNDIDADE DE CAMPO PEQUENO, MÉDIO E GRANDE FORMATO

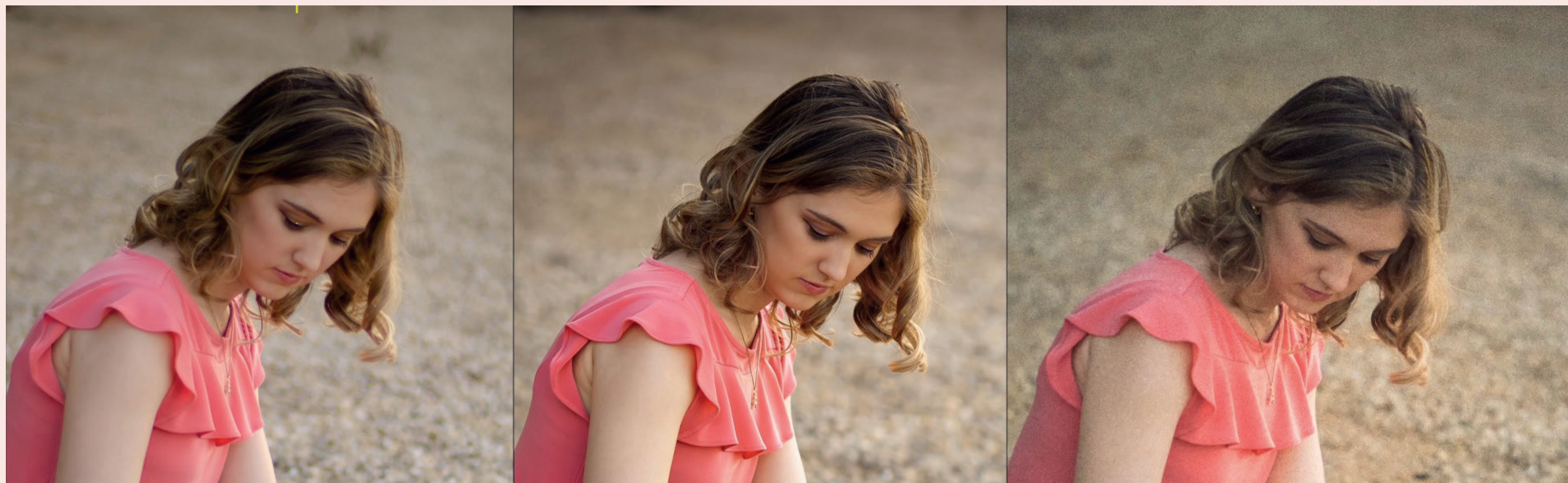

MESMA
PROFUNDIDADE

PEQUENO F.
50mm **f1.8**

MÉDIO F.
85mm **f3.3**

GRANDE F.
300mm **f12.7**

WEBCAM

Fonte: John Aldred

ACHATAMENTO DE PLANOS



24mm

Fonte: Exposure Therapy



50mm



105mm

WEBCAM

LENTE CATADIÓPTRICA OU REFLEXÍVEL



Fonte: Marco Cavina

WEBCAM

LENTE CATADIÓPTRICA OU REFLEXÍVEL

PONTO DE
CONVERGÊNCIA
FORA DA LENTE

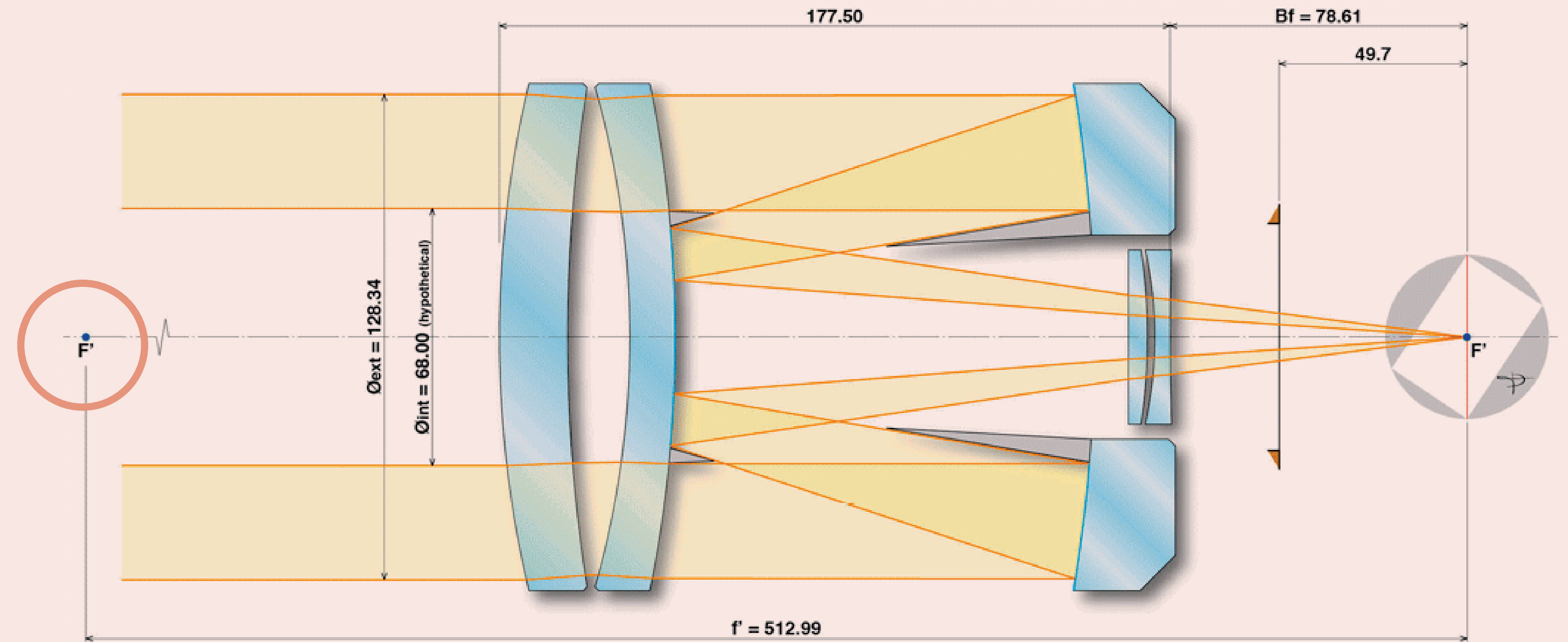

Fonte: Marco Cavina

WEBCAM

PROJETOS DELENTE

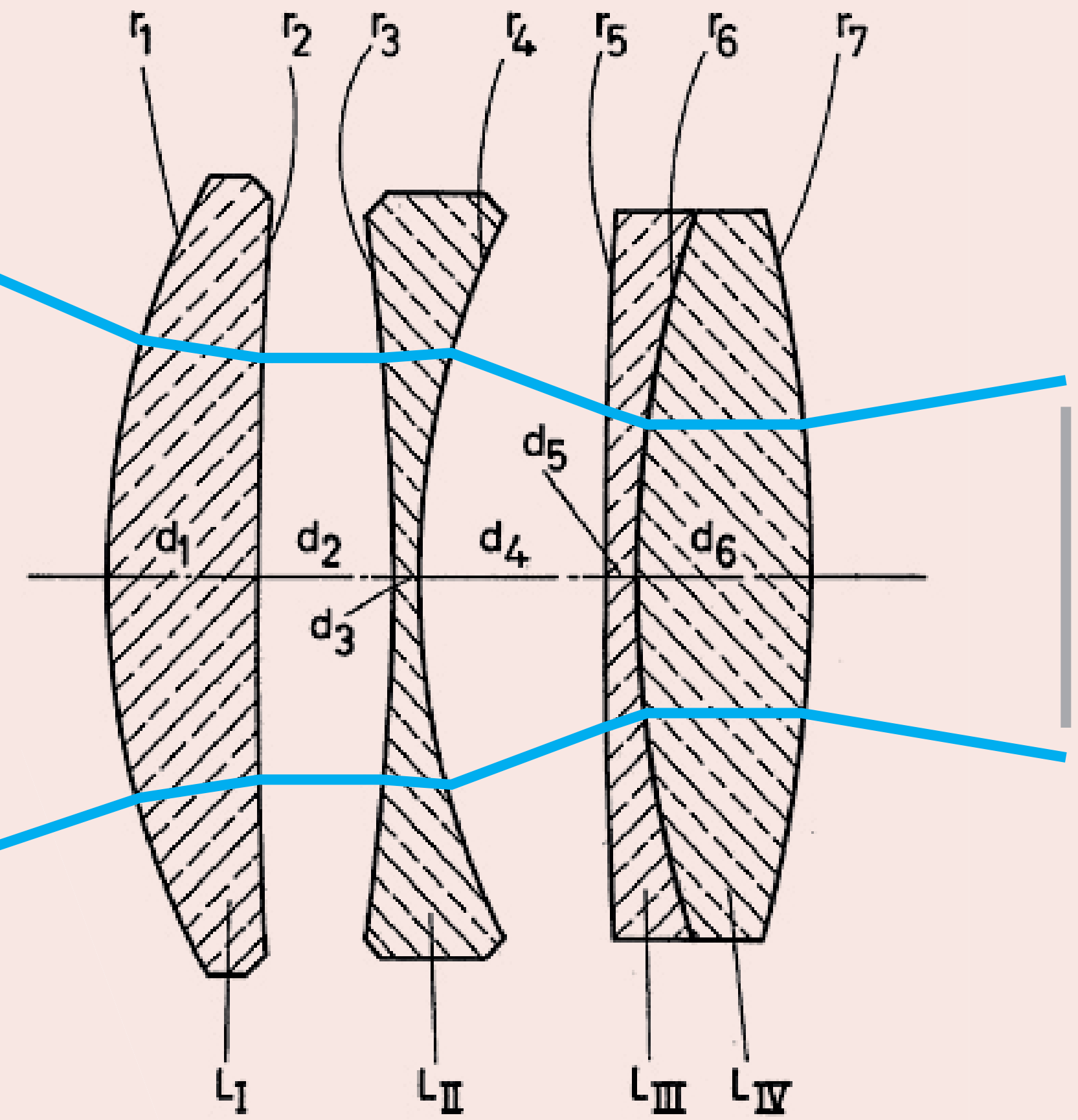

WEBCAM

Fonte: Marco Cavina

Carl Zeiss S-Planar 50mm f/1,6 4360 A° (1974) - 1.196 exemplars

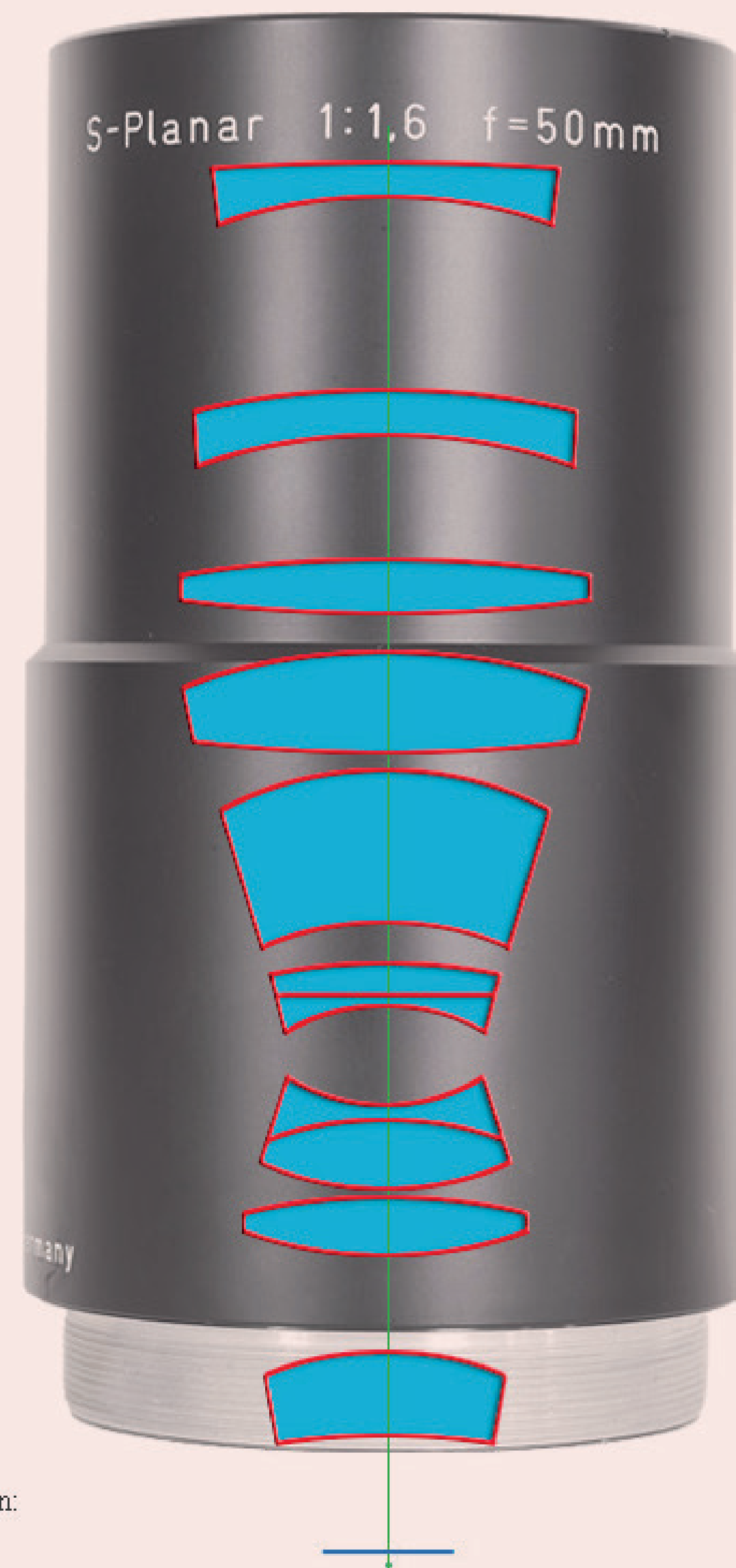
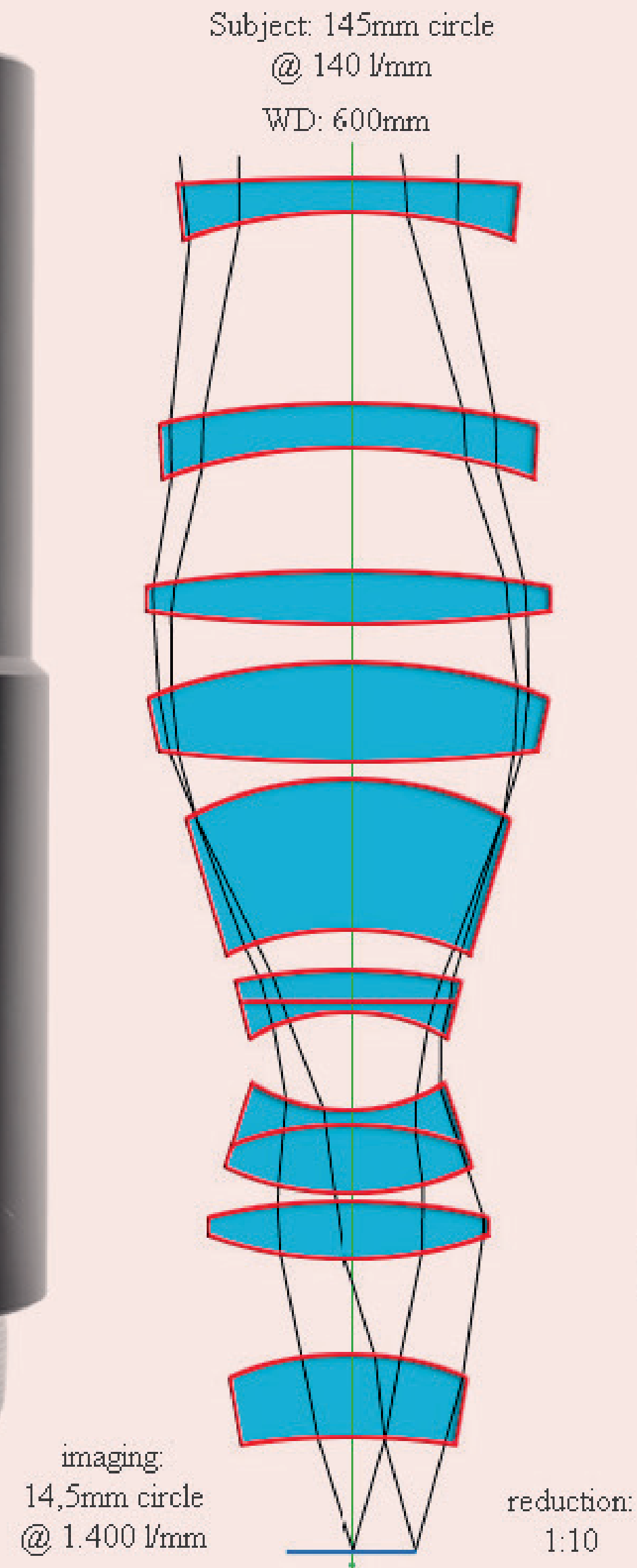

PROJETOS DE LENTE

Fonte: Marco Cavina

WEBCAM

TAMANHO DE LENTES DE MESMA SÉRIE



800mm



600mm



200-400mm



500mm



400mm



300mm

WEBCAM

COMPARATIVO DE PROJETOS DIFERENTES



**50mm f1.4
SIGMA ART**

**50mm f1.8
CANON STM**

WEBCAM

AJUSTE DE FOCO

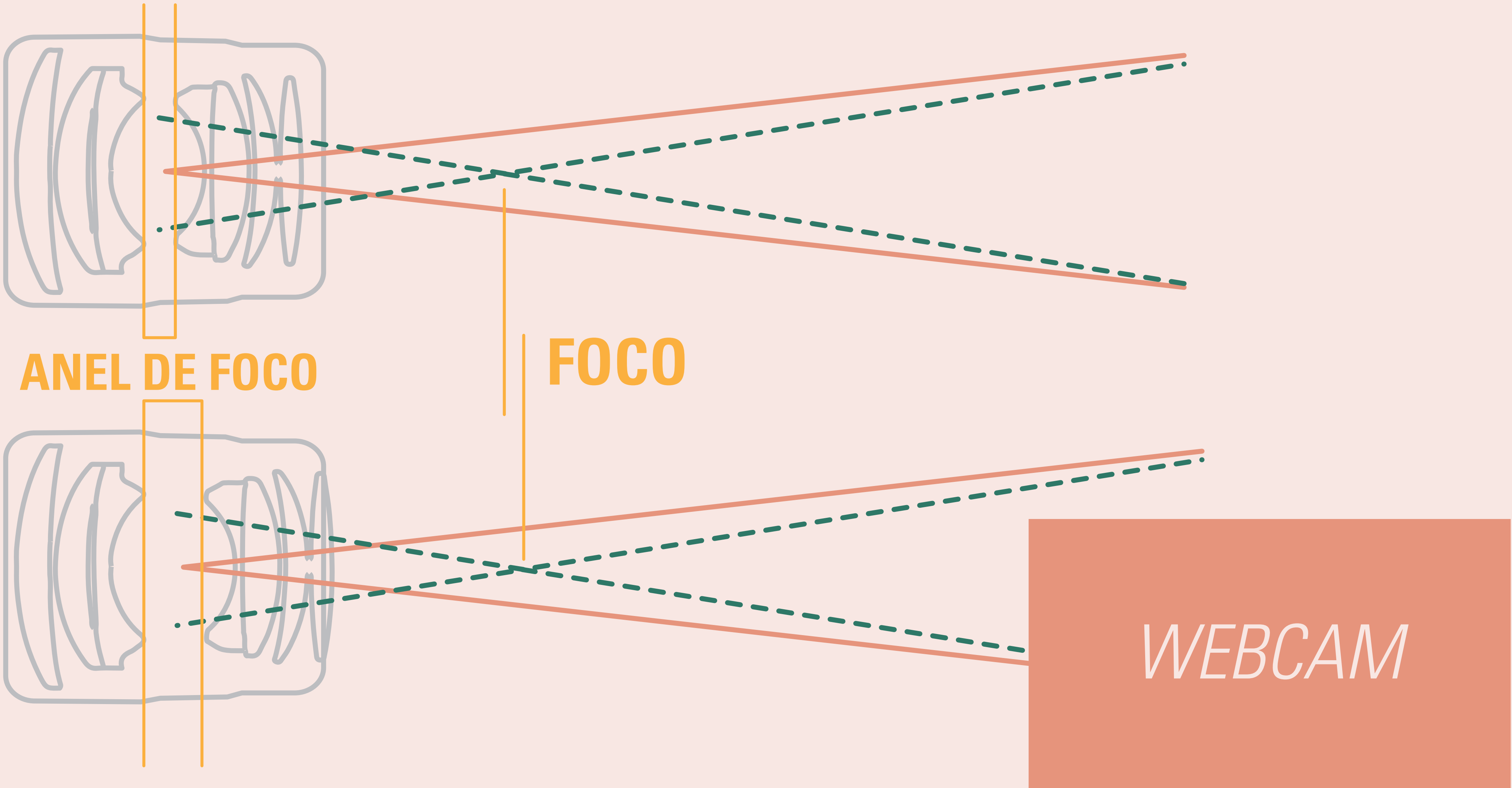

ESPECTRO DE LUZ VISÍVEL E INVISÍVEL

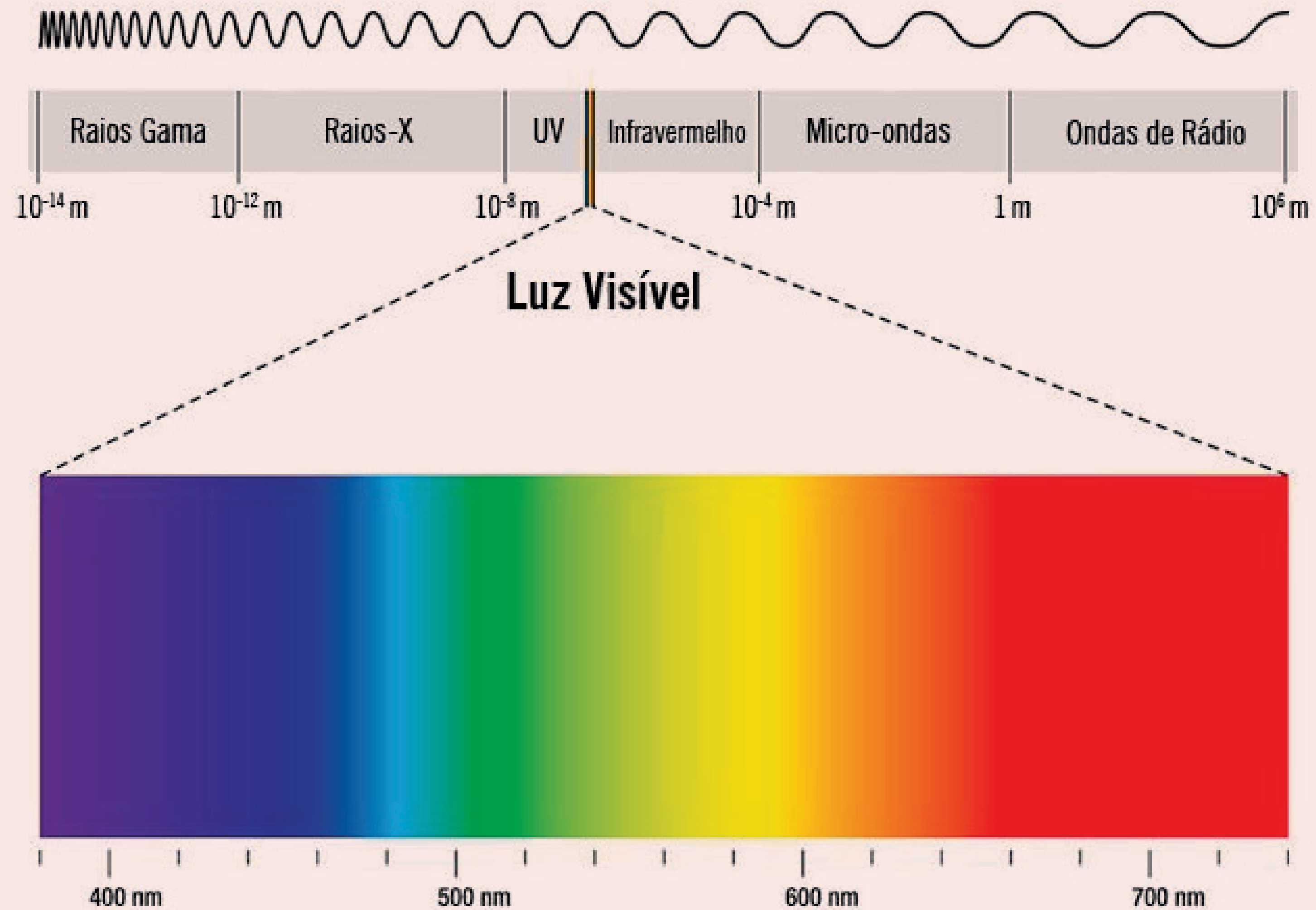

Fonte: Toda Matéria

WEBCAM

COATING

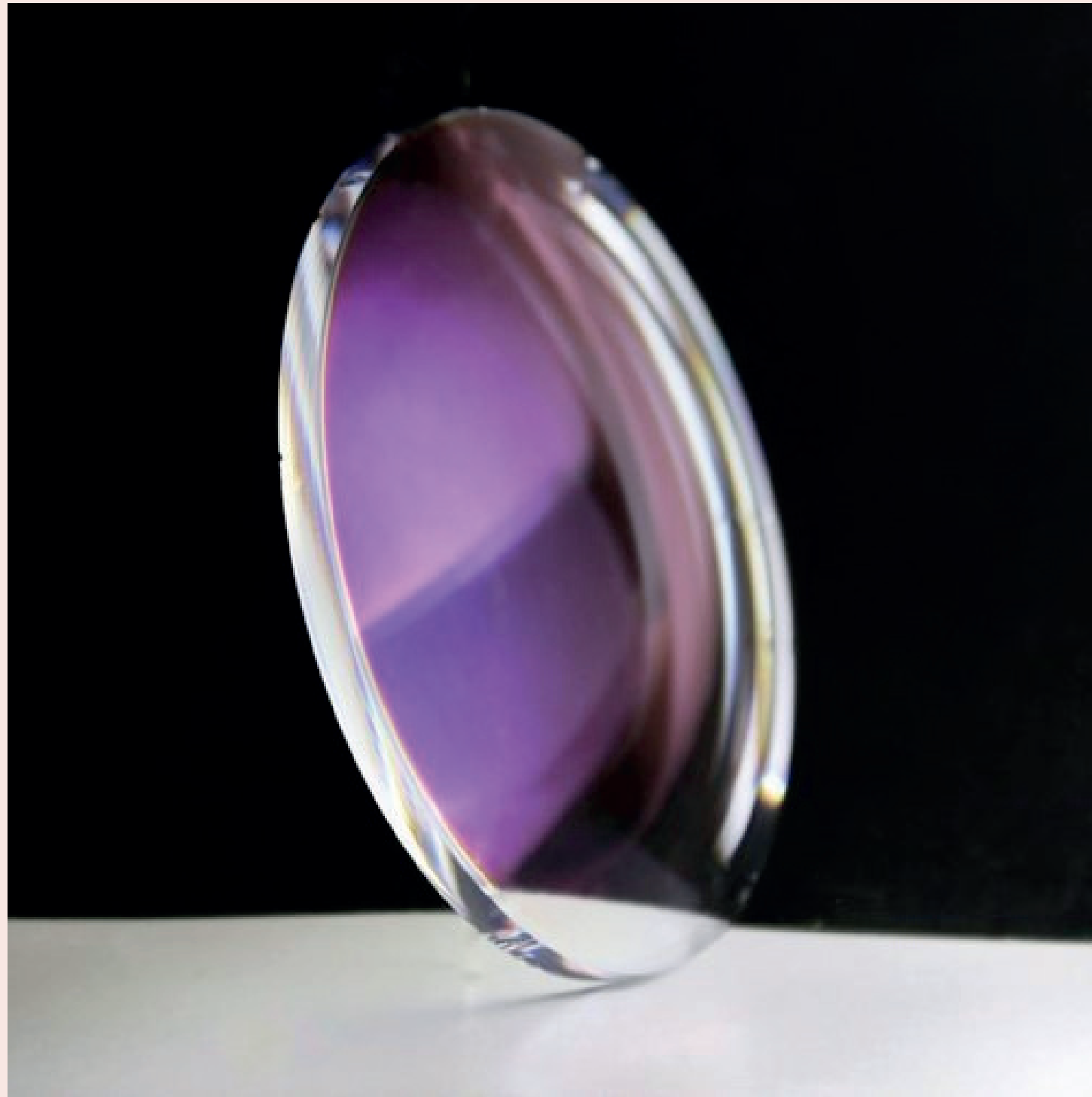

Fonte: IndiaMark



COM

SEM

**REVESTIMENTO
DOS ELEMENTOS
ÓTICOS COM
FUNÇÃO DE FILTRO**

Fonte: Markus Keinath

WEBCAM

FUNIONAMENTO DO COATING

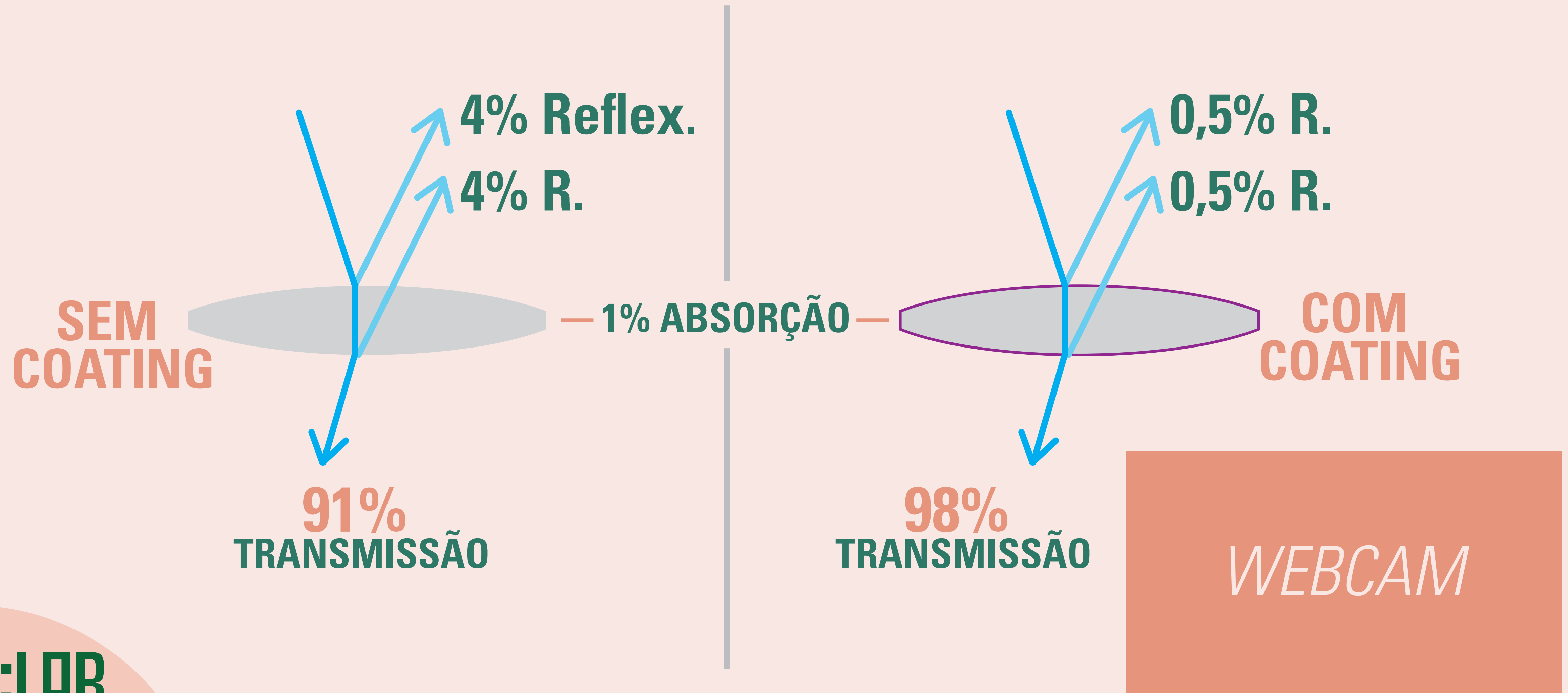

ABERRAÇÃO CROMÁTICA



Fonte: Wikipedia

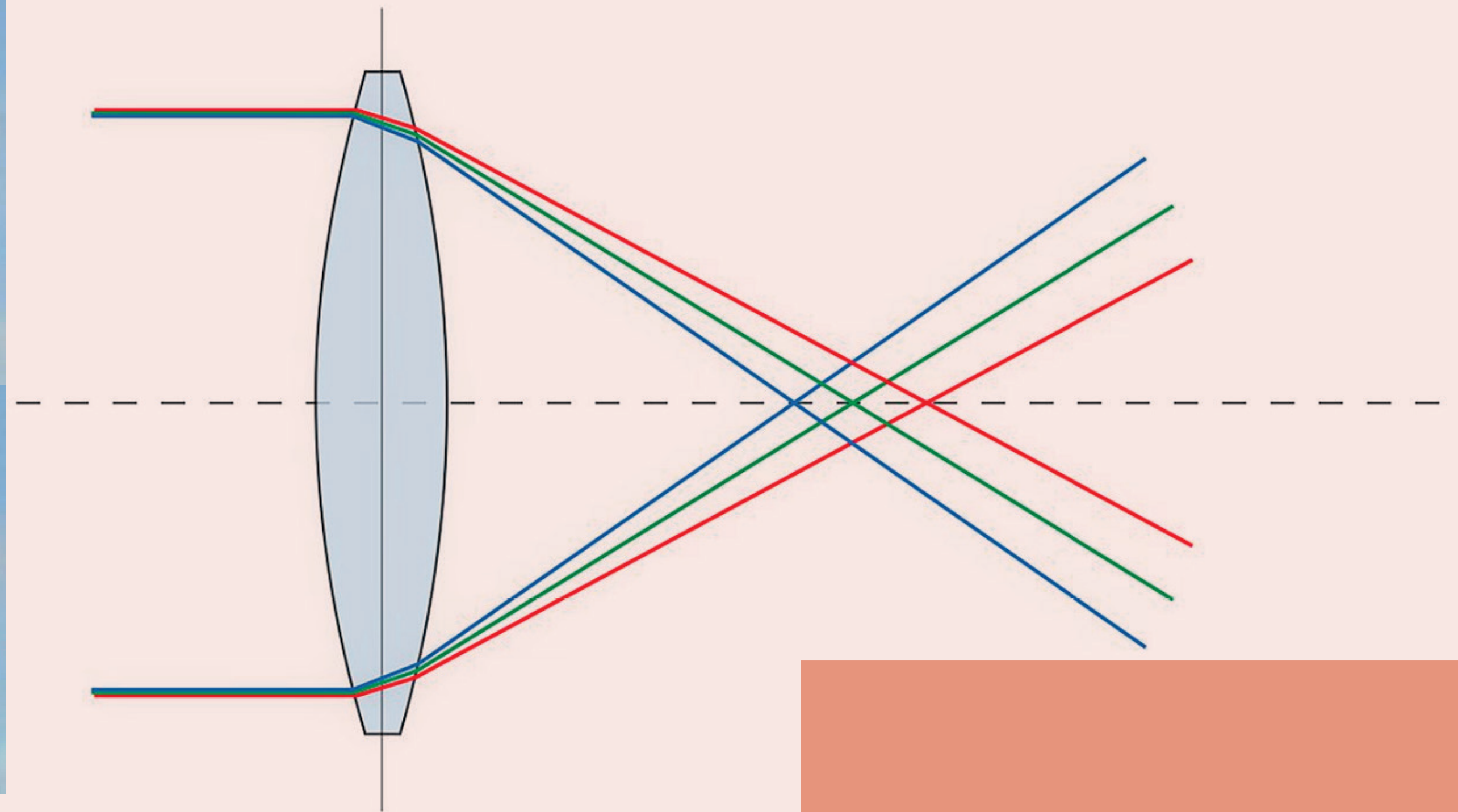

WEBCAM

FOTOGRAFIA INFRAVERMELHO



WEBCAM

PROFUNDIDADE DE CAMPO



WEBCAM

CABÔ, VALEU.

Conteúdo e ilustrações: Vitor Lopes Leite / Lab:Lab Analógico

Apresentado em 05 de Agosto de 2021 no Youtube.

Confira em: <https://youtu.be/ajC0Rpv1jDA>

LAB:LAB
ANALÓGICO

***www.lablab.com.br
[instagram.com/lab.lab_br](https://www.instagram.com/lab.lab_br)
[youtube.com/c/lablabanalogico](https://www.youtube.com/c/lablabanalogico)***

CC BY-NC-SA
Atribuição-NãoComercial-Compartilhalgual

